

Service Manual

Air Conditioner

CS-E15DB4EW CU-E15DBE
CS-E18DB4EW CU-E18DBE
CS-E21DB4ES CU-E21DBE



⚠ WARNING

This service information is designed for experienced repair technicians only and is not designed for use by the general public. It does not contain warnings or cautions to advise non-technical individuals of potential dangers in attempting to service a product. Products powered by electricity should be serviced or repaired only by experienced professional technicians. Any attempt to service or repair the product or products dealt with in this service information by anyone else could result in serious injury or death.

⚠ PRECAUTION OF LOW TEMPERATURE

In order to avoid frostbite, be assured of no refrigerant leakage during the installation or repairing of refrigeration circuit.

CONTENTS

	Page		Page
1 Features	2	4.2. Outdoor Unit	13
2 Functions	3	5 Refrigeration Cycle Diagram	14
2.1. Remote Control	3	6 Block Diagram	15
2.2. Indoor Unit	4	7 Wiring Diagram	16
2.3. Outdoor Unit	5	8 Operation Details	17
3 Product Specifications	6	8.1. Basic Operation	17
3.1. CS-E15DB4EW CU-E15DBE	6	8.2. Protection Control Features	28
3.2. CS-E18DB4EW CU-E18DBE	8	9 Operating Instructions	34
3.3. CS-E21DB4ES CU-E21DBE	10	10 Installation And Servicing Air Conditioner Using R410A	42
4 Dimensions	12	10.1. Outline	42
4.1. Indoor Unit & Remote Control	12	10.2. Tools For Installing/Servicing Refrigerant Piping	43

Panasonic®

© 2005 Panasonic HA Air-Conditioning (M) Sdn Bhd (11969-T). All rights reserved. Unauthorized copying and distribution is a violation of law.

10.3. Refrigerant Piping Work	47	14.1. CS-E15DB4EW CS-E18DB4EW CS-E21DB4ES	79
10.4. Installation, Transferring, Servicing	49	14.2. CZ-BT20E (Front Grille Complete)	81
11 Installation Instructions	53	15 Replacement Parts List (Indoor Unit)	82
11.1. Safety Precautions	53	15.1. CS-E15DB4EW CS-E18DB4EW CS-E21DB4ES	82
11.2. Indoor Unit	55	15.2. CZ-BT20E (Front Grille Complete)	83
11.3. Outdoor Unit	62	16 Exploded View (Outdoor Unit)	84
12 Servicing Information	66	16.1. CU-E15DBE CU-E18DBE CU-E21DBE	84
12.1. Troubleshooting	66	17 Replacement Parts List (Outdoor Unit)	85
12.2. Breakdown Self Diagnosis Function	68	17.1. CU-E15DBE CU-E18DBE CU-E21DBE	85
12.3. Remote Control	70	18 Electronic Circuit Diagram	86
12.4. Auto OFF/ON Button	71	18.1. Indoor Unit	86
12.5. Disassembly of Parts	72	18.2. Outdoor Unit	90
13 Technical Data	75	18.3. Remote Control	95
13.1. Operation Characteristics	75	18.4. Print PatternIndoor Unit Printed Circuit Board	96
13.2. Sensible Capacity Chart	78	18.5. Print PatternOutdoor Unit Printed Circuit Board View	97
14 Exploded View (Indoor Unit)	79		

1 Features

• Product

- Four modes of operation selection
- Powerful Mode operation
- 24-Hour Real Time Timer Control
- Quiet Mode Operation
- Discharged air can be swung automatically or manually by remote control
- Air filter with function to reduce dust and smoke.

• Serviceability Improvement

- Removable and washable Intake Grille
- Breakdown Self Diagnosis function

• Environmental Protection

- Non-ozone-depletion substances refrigerant (R410A)

• Quality Improvement

- Gas leakage detection
- Deice operation
- Auto restart control

2 Functions

2.1. Remote Control

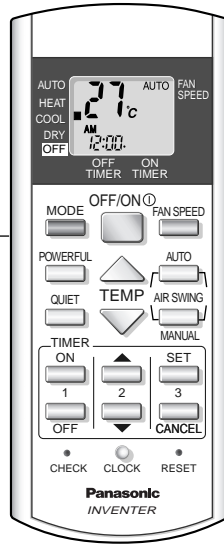

OFF / ON  **Operation OFF / ON**

MODE **Operation Mode Selection**

- AUTO Automatic Operation
- HEAT Heating Operation
- COOL Cooling Operation
- DRY Soft Dry Operation





POWERFUL **Powerful Mode Operation**

QUIET **Quiet Mode Operation**

AIR SWING **Airflow Direction Control**

- AUTO Vertical Automatic Airflow Direction Control.
- MANUAL Vertical Manual Airflow Direction Control.

FAN SPEED **Indoor Fan Speed Selection**

-  Low
-  Medium-low
-  Medium
-  Medium+
-  High
- AUTO Automatic Fan Speed

 TEMP

Room Temperature Setting

- Increase or decrease set temperature. (16°C to 30°C)

TIMER-ON
TIMER-OFF

Timer Setting

- 24-hour, OFF / ON Real Timer Setting.



Time / Timer Setting

- Hours and minutes setting.

SET
CANCEL

Timer Operation Set / Cancel

- ON Timer and OFF Timer setting and cancellation.

 CLOCK

Clock Setting

- Current time setting.

 CHECK

Check Point

- Breakdown self diagnosis function.

 RESET

Reset Point

- Clear memory data.

2.2. Indoor Unit



Automatic Operation Switch

- To run automatic operation, force cooling or heating operation, or change remote control signal type.

Operation Indication Lamps (LED)

- POWER (Green) Lights up in operation, blinks in Automatic Operation Mode judging, deice, On Timer sampling and Hot Start operation.
- TIMER (Orange) Lights up in Timer Setting. Blinks in Self Diagnosis Control.
- QUIET (Orange) Lights up in Quiet Mode Operation.
- POWERFUL (Orange) ... Lights up when Powerful Mode is selected.
- AIR SWING (Orange) Lights up in Auto Air Swing.

Four Operation Modes

- Automatic, Heating, Cooling and Soft Dry Operation.

Automatic and 5 Manual Indoor Fan Speeds

Airflow Direction Control

- Vertical discharged air can be swung automatically or manually by remote control.
- Horizontal discharged air can be adjusted by hand.

Powerful Mode

- For quick cooling or heating.

Quiet Mode

- To provide quiet operation.

24-Hour Real Time Timer Control

Automatic Restart Control

- Operation is restarted after power failure at previous setting mode.

Microcomputer-controlled Room Temperature Control

Breakdown Self Diagnosis Function

Low Pressure Control (Gas Leakage Detection)

Indoor Power Relay Control

Anti-Dew Formation Control

Anti Freezing Control

Anti-Cold Draft Control

Hot Start

Intake Air Temperature Control

High Pressure Control

Deodorizing Control

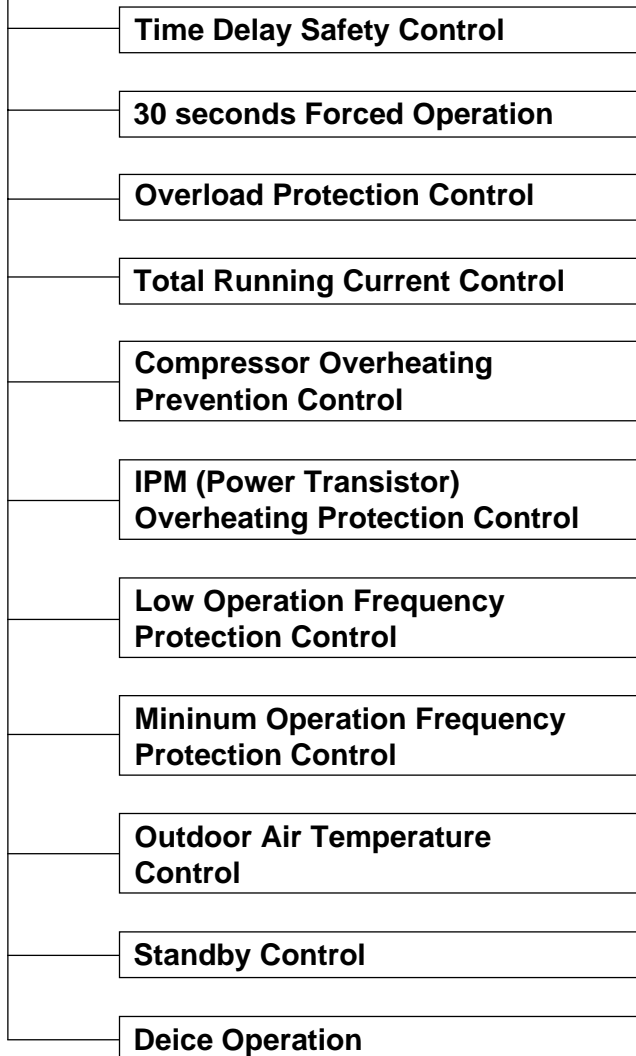
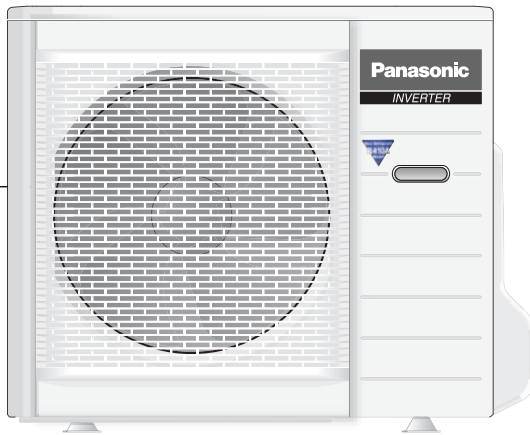

Deice Operation

2.3. Outdoor Unit



3 Product Specifications

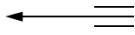

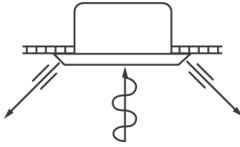
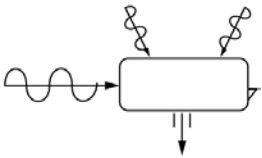
3.1. CS-E15DB4EW CU-E15DBE

		Unit	CS-E15DB4EW	CU-E15DBE
Cooling Capacity		kW kcal/h BTU/h	4.10 (0.90 - 4.80) 3,530 (770 - 4,130) 14,000 (3,070 - 16,400)	
Heating Capacity		kW kcal/h BTU/h	5.10 (0.90 - 6.20) 4,390 (770 - 5,330) 17,400 (3,070 - 21,100)	
Moisture Removal		l/h Pint/h	2.3 (4.9)	
Power Source (Phase, Voltage, Cycle)		ø V Hz	Single 230 - 240 50	
Airflow Method		<p>OUTLET</p>  <p>INTAKE</p> 	<p>SIDE VIEW</p> 	<p>TOP VIEW</p> 
Air Volume	Lo	m ³ /min (cfm)	Cooling; 7.5 (260) Heating; 9.0 (320)	—
	Me	m ³ /min (cfm)	Cooling; 9.0 (320) Heating; 10.1 (360)	—
	Hi	m ³ /min (cfm)	Cooling; 10.5 (370) Heating; 10.8 (380)	Cooling; 46.8 (1,650) Heating; 48.5 (1,710)
Noise Level		dB (A)	Cooling; High 34, Low 26 Heating; High 35, Low 28	Cooling; 45 Heating; 47
		Power level dB	Cooling; High 47 Heating; High 48	Cooling; High 58 Heating; High 60
Electrical Data	Input Power	W	Cooling; 1,300 (255 - 1,710) Heating; 1,770 (260 - 2,180)	
	Running Current	A	Cooling; 6.0 - 5.9 Heating; 8.0 - 7.9	
	EER	W/W	Cooling; 3.15 (3.53 - 2.81)	
		BTU/hW	Cooling; 10.8 (12.0 - 9.6)	
	COP	W/W	Heating; 2.88 (3.46 - 2.84)	
		BTU/hW	Heating; 9.8 (11.8 - 9.7)	
Starting Current	A	8.0		
Piping Connection Port (Flare piping)		inch inch	G ; Half Union 1/2" L ; Half Union 1/4"	G ; 3-way valve 1/2" L ; 2-way valve 1/4"

		Unit	CS-E15DB4EW	CU-E15DBE	
Pipe Size (Flare piping)		inch inch	G (gas side) ; 1/2" L (liquid side) ; 1/4"	G (gas side) ; 1/2" L (liquid side) ; 1/4"	
Drain Hose	Inner diameter	mm	30	—	
	Length	m	0.193	—	
Power Cord Length			—	—	
Number of core-wire			—	—	
Dimensions	Height	inch (mm)	10 - 1/4 (260)	29 - 17/32 (750)	
	Width	inch (mm)	22 - 5/8 (575)	34 - 7/16 (875)	
	Depth	inch (mm)	22 - 5/8 (575)	13 - 19/32 (345)	
Net Weight		lb (kg)	40 (18)	106 (48)	
Compressor	Type		—	Involute scroll	
	Motor Type		—	Brushless (4-pole)	
	Rated Output	W	—	900	
Air Circulation	Type		Backward Fan	Propeller Fan	
	Material		ABS + GF 10%	P.P	
	Motor Type		DC Brushless Motor (8-poles)	Transistor (8-poles)	
	Rate Output	W	40	40	
	Fan Speed	Lo (Cool/Heat)	rpm	400 / 480	—
		Me (Cool/Heat)	rpm	480 / 540	—
Hi (Cool/Heat)		rpm	560 / 600	640 / 660	
Heat Exchanger	Description		Evaporator	Condenser	
	Tube material		Copper	Copper	
	Fin material		Aluminium (Pre Coat)	Aluminium	
	Fin Type		Slit Fin	Corrugated Fin	
	Row / Stage		(Plate fin configuration, forced draft) 2 / 10	1 / 28	
	FPI		18	18	
	Size (W x H x L)	mm	1,330 x 210 x 25.4 1,270	871.7 x 711.2 x 22	
Refrigerant Control Device			—	Expansion Valve	
Refrigeration Oil		(cm ³)	—	RB68A (400)	
Refrigerant (R410A)		kg (oz)	—	1.23 (43.4)	
Thermostat			Electronic Control	—	
Protection Device			Electronic Control	Electronic Control	

- Specifications are subjected to change without notice for further improvement.

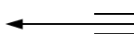
3.2. CS-E18DB4EW CU-E18DBE

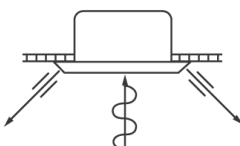
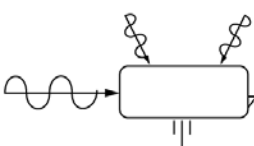
		Unit	CS-E18DB4EW	CU-E18DBE
Cooling Capacity		kW kcal/h BTU/h	4.80 (0.90 - 5.70) 4,130 (770 - 4,900) 16,400 (3,070 - 19,400)	
Heating Capacity		kW kcal/h BTU/h	5.60 (0.90 - 7.10) 4,820 (770 - 6,110) 19,100 (3,070 - 24,200)	
Moisture Removal		l/h Pint/h	2.6 (5.5)	
Power Source (Phase, Voltage, Cycle)		ø V Hz	Single 230 - 240 50	
Airflow Method		<p>OUTLET</p>  <p>INTAKE</p> 	<p>SIDE VIEW</p> 	<p>TOP VIEW</p> 
Air Volume	Lo	m ³ /min (cfm)	Cooling; 8.0 (280) Heating; 9.1 (320)	—
	Me	m ³ /min (cfm)	Cooling; 9.5 (340) Heating; 10.4 (370)	—
	Hi	m ³ /min (cfm)	Cooling; 11.0 (390) Heating; 11.5 (405)	40.0 (1,410)
Noise Level		dB (A)	Cooling; High 36, Low 28 Heating; High 37, Low 29	Cooling; 47 Heating; 48
		Power level dB	Cooling; High 49 Heating; High 50	Cooling; High 60 Heating; High 61
Electrical Data	Input Power	W	Cooling; 1,530 (255 - 1,930) Heating; 1,900 (260 - 2,450)	
	Running Current	A	Cooling; 7.0 - 6.9 Heating; 8.5 - 8.3	
	EER	W/W	Cooling; 3.14 (3.53 - 2.95)	
		BTU/hW	Cooling; 10.7 (12.0 - 10.1)	
	COP	W/W	Heating; 2.95 (3.46 - 2.90)	
		BTU/hW	Heating; 10.1 (11.8 - 9.9)	
Starting Current	A	8.5		
Piping Connection Port (Flare piping)		inch inch	G ; Half Union 1/2" L ; Half Union 1/4"	G ; 3-way valve 1/2" L ; 2-way valve 1/4"
Pipe Size (Flare piping)		inch inch	G (gas side) ; 1/2" L (liquid side) ; 1/4"	G (gas side) ; 1/2" L (liquid side) ; 1/4"

		Unit	CS-E18DB4EW	CU-E18DBE	
Drain Hose	Inner diameter	mm	30	—	
	Length	m	0.193	—	
Power Cord Length			—	—	
Number of core-wire			—	—	
Dimensions	Height	inch (mm)	10 - 1/4 (260)	29 - 17/32 (750)	
	Width	inch (mm)	22 - 5/8 (575)	34 - 7/16 (875)	
	Depth	inch (mm)	22 - 5/8 (575)	13 - 19/32 (345)	
Net Weight		lb (kg)	40 (18)	106 (48)	
Compressor	Type		—	Involute scroll	
	Motor Type		—	Brushless (4-pole)	
	Rated Output	W	—	900	
Air Circulation	Type		Backward Fan	Propeller Fan	
	Material		ABS + GF 10%	P.P	
	Motor Type		DC Brushless Motor (8-poles)	Transistor (8-poles)	
	Rate Output	W	40	40	
	Fan Speed	Lo (Cool/Heat)	rpm	430 / 490	—
		Me (Cool/Heat)	rpm	510 / 560	—
Hi (Cool/Heat)		rpm	590 / 640	660 / 660	
Heat Exchanger	Description		Evaporator	Condenser	
	Tube material		Copper	Copper	
	Fin material		Aluminium (Pre Coat)	Aluminium	
	Fin Type		Slit Fin	Corrugated Fin	
	Row / Stage		(Plate fin configuration, forced draft) 2 / 10	2 / 34	
	FPI		18	16	
	Size (W x H x L)	mm	1,330 x 210 x 25.4 1,270	849.3 x 714 x 36.4 878	
Refrigerant Control Device			—	Expansion Valve	
Refrigeration Oil		(cm ³)	—	RB68A (400)	
Refrigerant (R410A)		kg (oz)	—	1.06 (37.4)	
Thermostat			Electronic Control	—	
Protection Device			Electronic Control	Electronic Control	

- Specifications are subjected to change without notice for further improvement.

3.3. CS-E21DB4ES CU-E21DBE

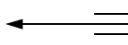
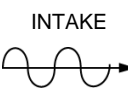
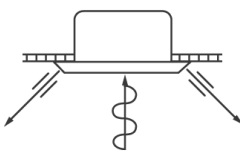
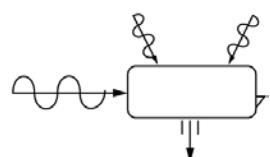
		Unit	CS-E21DB4ES	CU-E21DBE
Cooling Capacity		kW kcal/h BTU/h	5.90 (0.90 - 6.30) 5,070 (770 - 5,420) 20,100 (3,070 - 21,500)	
Heating Capacity		kW kcal/h BTU/h	7.00 (0.90 - 8.00) 6,020 (770 - 6,880) 23,900 (3,070 - 27,300)	
Moisture Removal		l/h Pint/h	3.3 (7.0)	
Power Source (Phase, Voltage, Cycle)		ø V Hz	Single 230 - 240 50	
Airflow Method		<p>OUTLET</p>  <p>INTAKE</p> 	<p>SIDE VIEW</p> 	<p>TOP VIEW</p> 
Air Volume	Lo	m ³ /min (cfm)	Cooling; 9.3 (330) Heating; 10.6 (370)	—
	Me	m ³ /min (cfm)	Cooling; 11.0 (390) Heating; 12.3 (430)	—
	Hi	m ³ /min (cfm)	Cooling; 12.8 (450) Heating; 14.0 (495)	Cooling; 42.8 (1,510) Heating; 41.5 (1,460)
Noise Level		dB (A)	Cooling; High 41, Low 33 Heating; High 42, Low 34	Cooling; 49 Heating; 49
		Power level dB	Cooling; High 54 Heating; High 55	Cooling; High 62 Heating; High 62
Electrical Data	Input Power	W	Cooling; 2,050 (255 - 2,200) Heating; 2,450 (260 - 2,820)	
	Running Current	A	Cooling; 9.2 - 9.0 Heating; 10.9 - 10.6	
	EER	W/W	Cooling; 2.88 (3.53 - 2.86)	
		BTU/hW	Cooling; 9.8 (12.0 - 9.8)	
	COP	W/W	Heating; 2.86 (3.46 - 2.84)	
		BTU/hW	Heating; 9.8 (11.8 - 9.7)	
Starting Current	A	10.9		
Piping Connection Port (Flare piping)		inch inch	G ; Half Union 1/2" L ; Half Union 1/4"	G ; 3-way valve 1/2" L ; 2-way valve 1/4"
Pipe Size (Flare piping)		inch inch	G (gas side) ; 1/2" L (liquid side) ; 1/4"	G (gas side) ; 1/2" L (liquid side) ; 1/4"

		Unit	CS-E21DB4ES	CU-E21DBE	
Drain Hose	Inner diameter	mm	30	—	
	Length	m	0.193	—	
Power Cord Length			—	—	
Number of core-wire			—	—	
Dimensions	Height	inch (mm)	10 - 1/4 (260)	29 - 17/32 (750)	
	Width	inch (mm)	22 - 5/8 (575)	34 - 7/16 (875)	
	Depth	inch (mm)	22 - 5/8 (575)	13 - 19/32 (345)	
Net Weight		lb (kg)	40 (18)	108 (49)	
Compressor	Type		—	Involute scroll	
	Motor Type		—	Brushless (4-pole)	
	Rated Output	W	—	900	
Air Circulation	Type		Backward Fan	Propeller Fan	
	Material		ABS + GF 10%	P.P	
	Motor Type		DC Brushless Motor (8-poles)	Transistor (8-poles)	
	Rate Output	W	40	40	
	Fan Speed	Lo (Cool/Heat)	rpm	510 / 580	—
		Me (Cool/Heat)	rpm	600 / 670	—
Hi (Cool/Heat)		rpm	700 / 770	700 / 680	
Heat Exchanger	Description		Evaporator	Condenser	
	Tube material		Copper	Copper	
	Fin material		Aluminium (Pre Coat)	Aluminium	
	Fin Type		Slit Fin	Corrugated Fin	
	Row / Stage		(Plate fin configuration, forced draft) 2 / 10	2 / 34	
	FPI		18	18	
	Size (W x H x L)	mm	1,330 x 210 x 25.4 1,270	839.5 x 714 x 36.4 868	
Refrigerant Control Device			—	Expansion Valve	
Refrigeration Oil		(cm ³)	—	RB68A (400)	
Refrigerant (R410A)		kg (oz)	—	1.15 (40.6)	
Thermostat			Electronic Control	—	
Protection Device			Electronic Control	Electronic Control	

- Specifications are subjected to change without notice for further improvement.

4 Dimensions

4.1. Indoor Unit & Remote Control

4.1.1. CS-E15DB4EW CS-E18DB4EW CS-E21DB4ES

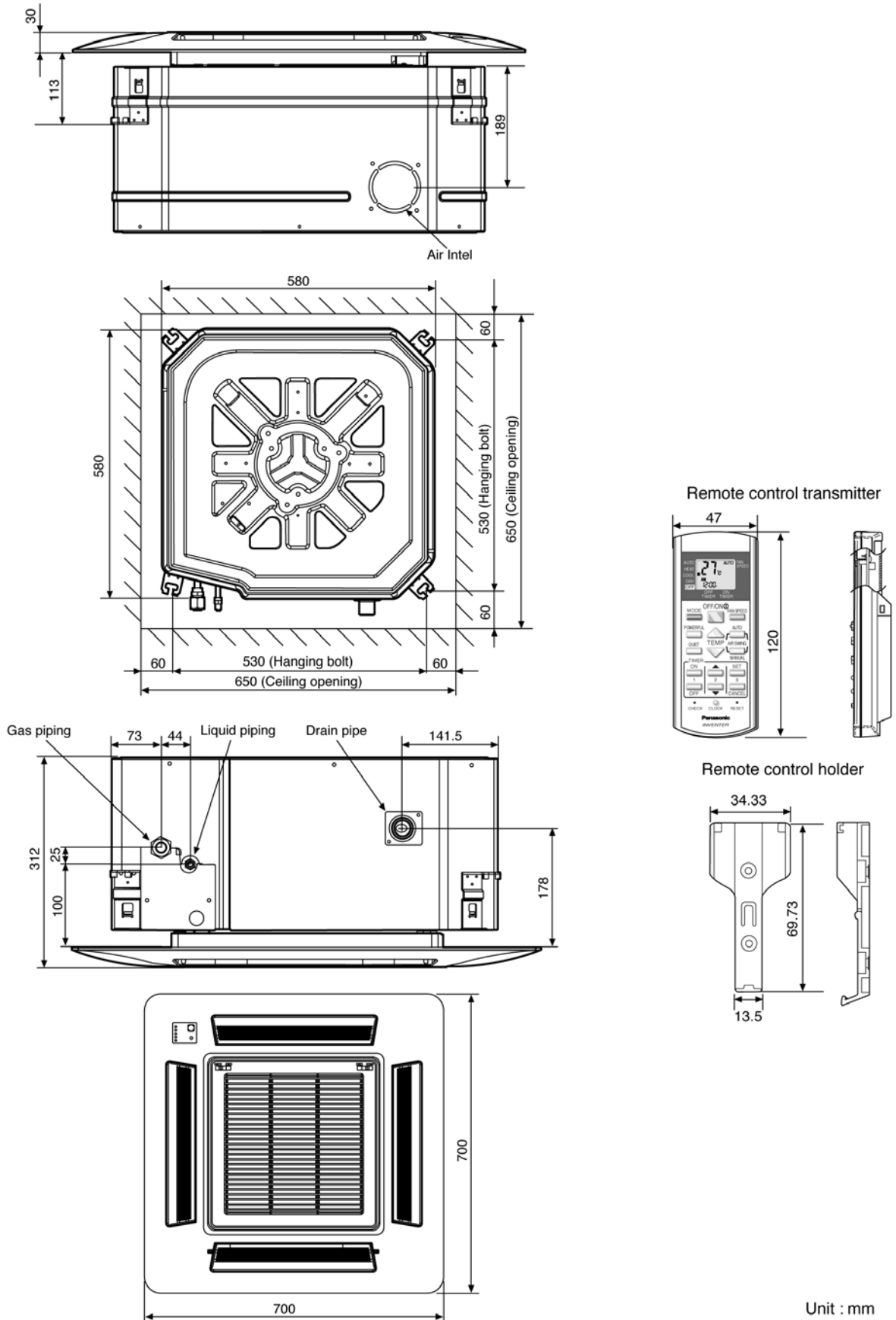

Unit : mm

4.2. Outdoor Unit

4.2.1. CU-E15DBE CU-E18DBE CU-E21DBE

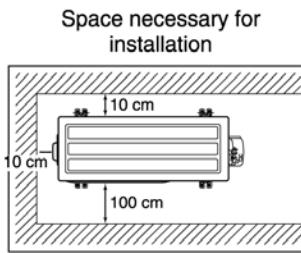

Anchor Bolt Pitch
383 x 612.5

<Top View>

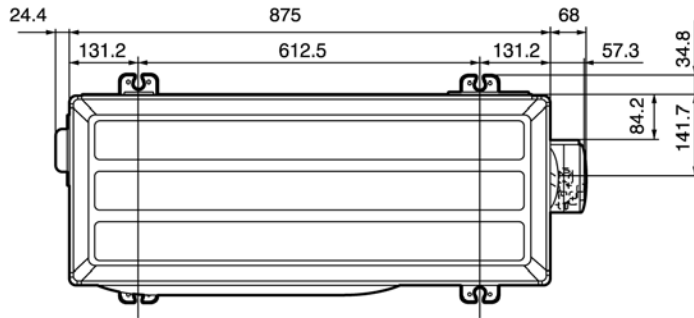

<Side View>

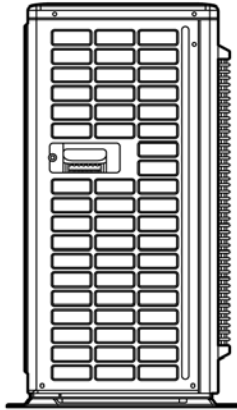

<Front View>

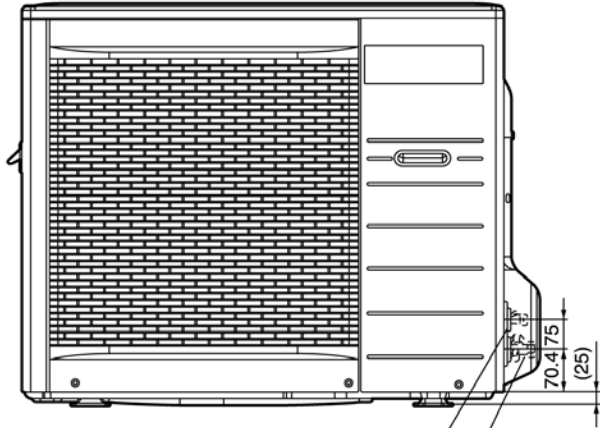

<Side View>

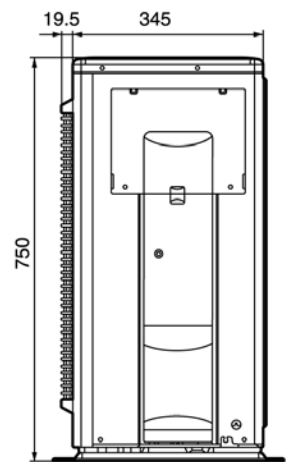

3-way valve at Gas side
(Low Pressure)

2-way valve at Liquid side
(High Pressure)

Unit: mm

5 Refrigeration Cycle Diagram

CS-E15DB4EW CU-E15DBE
CS-E18DB4EW CU-E18DBE
CS-E21DB4ES CU-E21DBE

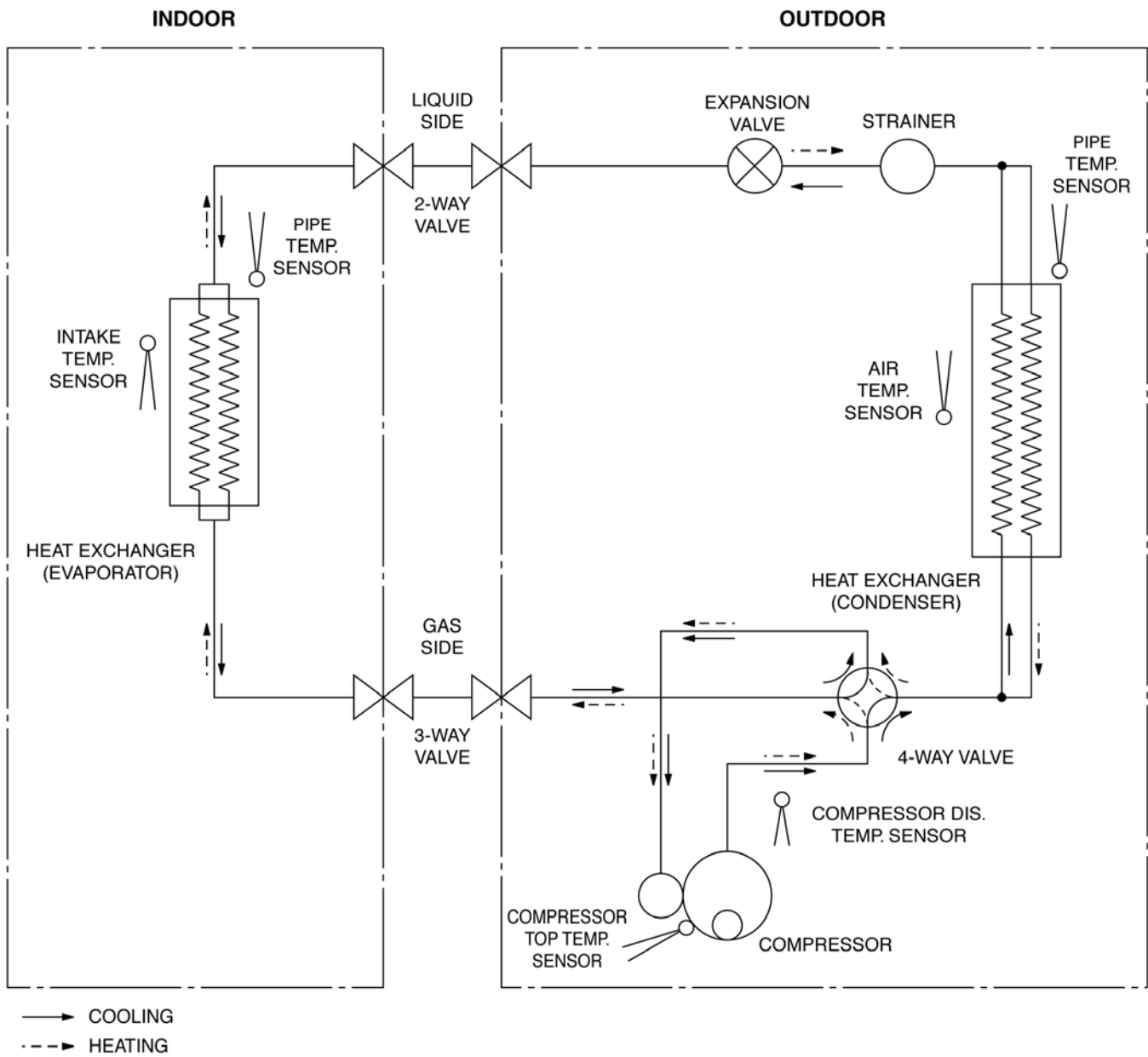

Model	Piping size		Rated Length (m)	Common Length (m)	Max. Elevation (m)	Max. Piping Length (m)	Additional Refrigerant (g/m)
	Gas	Liquid					
E15D	1/2"	1/4"	7.5	10	15	20	20
E18D, E21D	1/2"	1/4"	5	10	15	20	20

※ If piping length is over common length, additional refrigerant should be added as shown in the table.

6 Block Diagram

CS-E15DB4EW CU-E15DBE
 CS-E18DB4EW CU-E18DBE
 CS-E21DB4ES CU-E21DBE

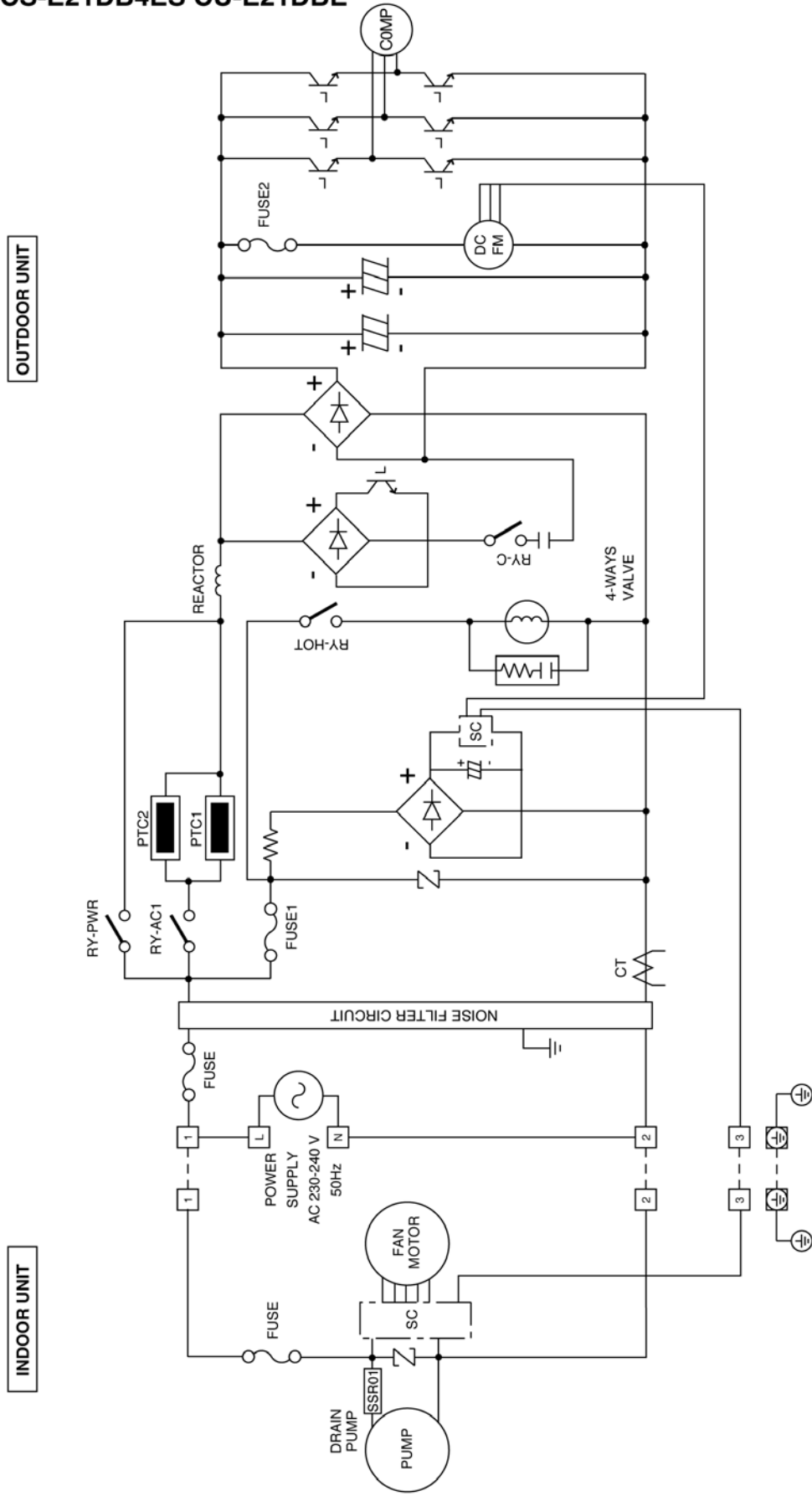

✳ [] Indicates the electronic control unit.

7 Wiring Diagram

CS-E15DB4EW CU-E15DBE
CS-E18DB4EW CU-E18DBE
CS-E21DB4ES CU-E21DBE

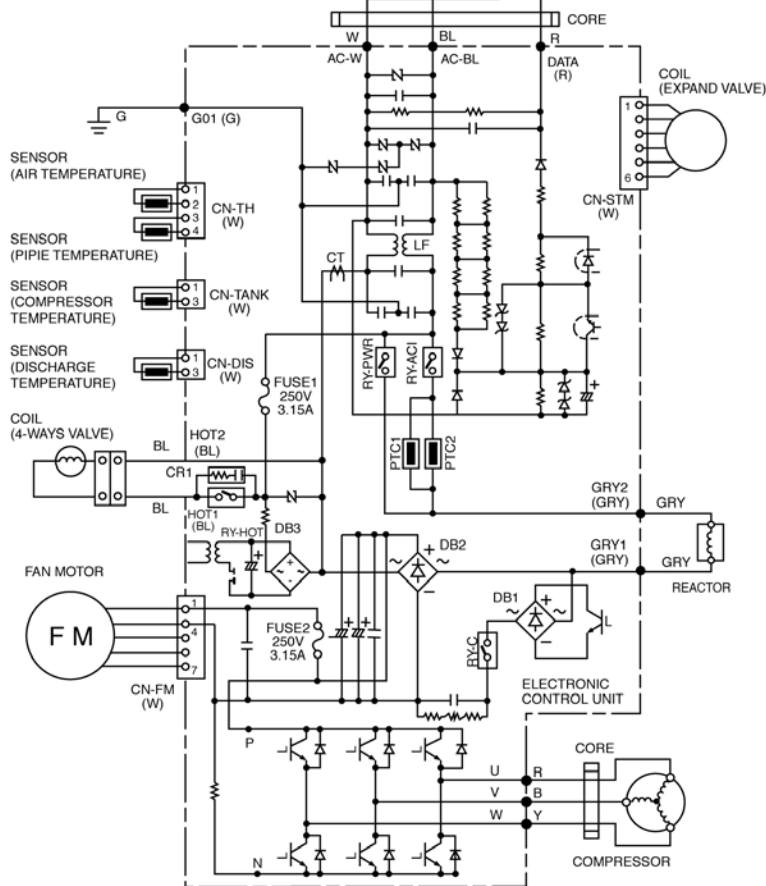
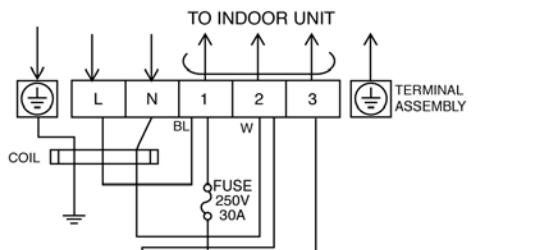
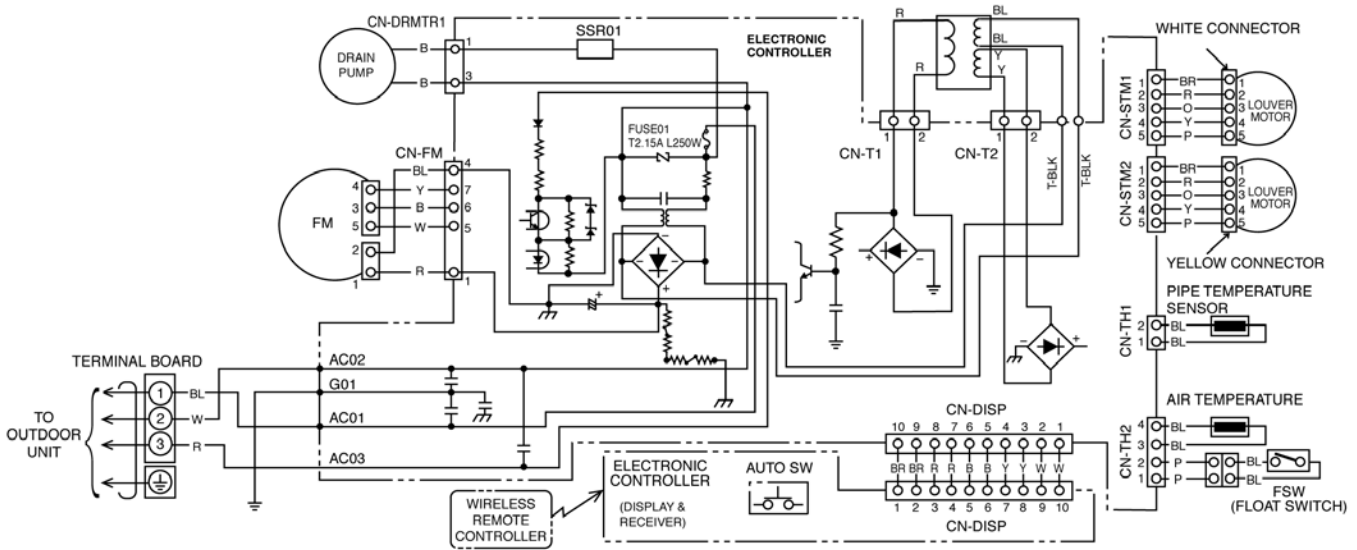

Remarks:

- B : BLUE
- BR : BROWN
- BL : BLACK
- W : WHITE
- G : GREEN
- R : RED
- O : ORANGE
- P : PINK
- VLT : VIOLET
- GRY : GRAY
- Y/G : YELLOW / GREEN

Resistance of Compressor Windings

CONNECTION	5CS130XAD04 (Ω)
U - V	0.9
V - W	0.9
U - W	0.9

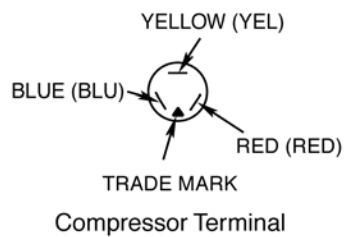

8 Operation Details

8.1. Basic Operation

Inverter control, which equipped with a microcomputer in determining the most suitable operating mode as time passes, automatically adjust output power for maximum comfort always.

In order to achieve the suitable operation mode, the microcomputer maintains the set temperature by measuring the temperature of environment and performing temperature shifting.

8.1.1. Temperature Shifting Flow

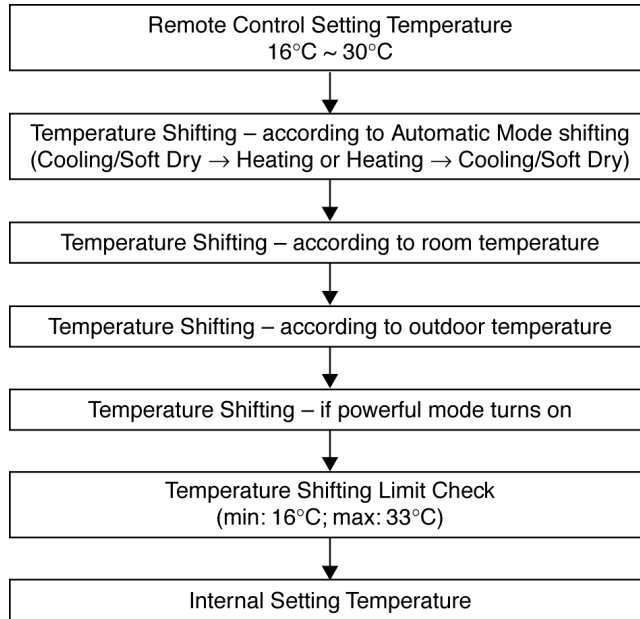

The compressor at outdoor unit is operating following the frequency instructed by the microcomputer at indoor unit that judging the condition according to internal setting temperature.

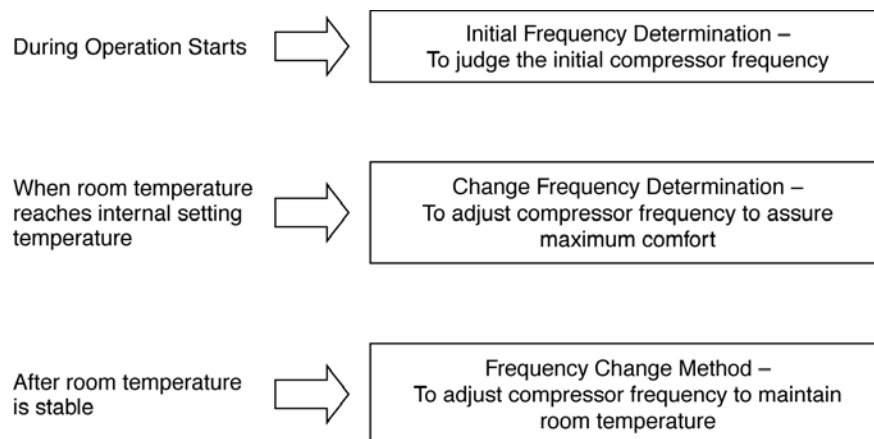

8.1.2. Cooling Operation

8.1.2.1. Thermostat control

- Compressor is OFF when Intake Air Temperature - Internal Setting Temperature < -1.5°C.
- Compressor is ON after waiting for 3 minutes, if the Intake Air Temperature - Internal Setting Temperature > Compressor OFF point.

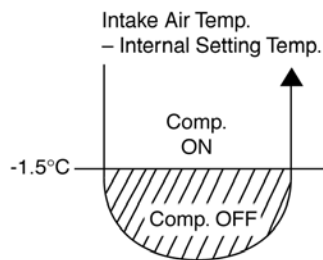

8.1.3. Soft Dry Operation

8.1.3.1. Thermostat control

- Compressor is OFF when Intake Air Temperature - Internal Setting Temperature < -2.0°C.
- Compressor is ON after waiting for 3 minutes, if the Intake Air Temperature - Internal Setting Temperature > Compressor OFF point.

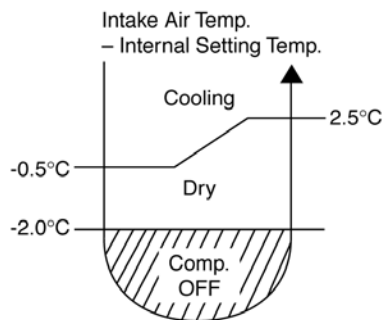

8.1.4. Heating Operation

8.1.4.1. Thermostat control

- Compressor is OFF when Intake Air Temperature - Internal Setting Temperature > +2.0°C.
- Compressor is ON after waiting for 3 minutes, if the Intake Air Temperature - Internal Setting Temperature < Compressor OFF point.

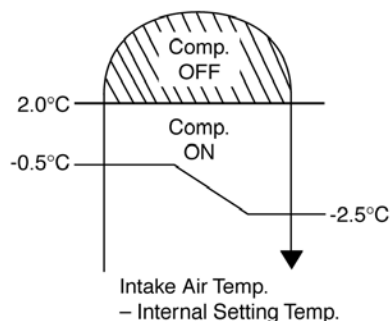

8.1.5. Automatic Operation

This mode can be set using remote control and the operation is decided by remote control setting temperature, indoor intake air temperature and outdoor air temperature.

During operation mode judgment, indoor fan motor (with speed of Lo-) and outdoor fan motor are running for 30 seconds to detect the indoor intake and outdoor air temperature. The operation mode is decided based on below chart.

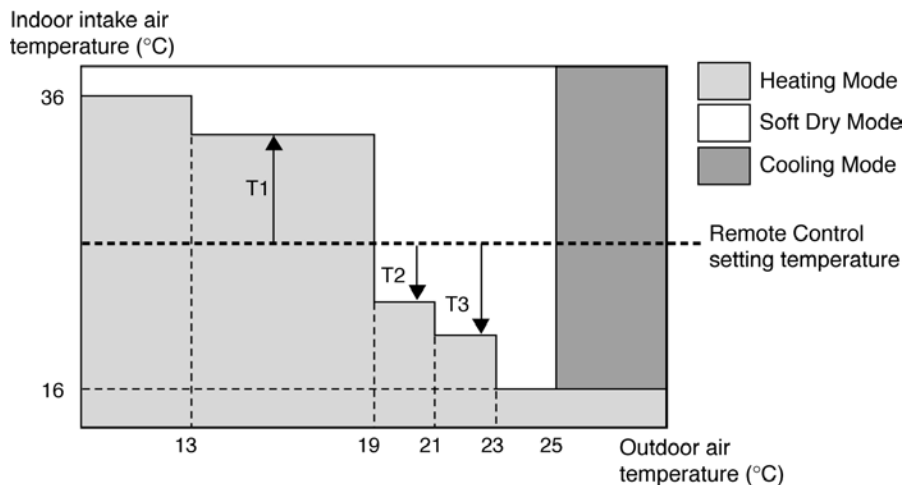

Values of T1, T2, and T3 depend on remote control setting temperature, as shown in below table. After the adjustment of T1, T2 and T3 values, the operation mode for that particular environment and remote control setting is judged and performed, based on the above operation mode chart, every 30 minutes.

Remote Control Setting Temperature (°C)	T1	T2	T3
16 ~ 18	+10	-3	-5
19 ~ 22	+8	-3	-7
23 ~ 26	+7	-3	-7
27 ~ 30	+6	-3	-8

There is a temperature shifting on T1, T2, and T3 if the operation mode judged is changed from Cooling/Soft Dry to Heating or vice verse.

Operation Mode change from	Temperature shifts (°C)
Cooling/Soft Dry → Heating	-2
Heating → Cooling/Soft Dry	+2

Example of operation mode chart adjustment:

From the above table, if remote control setting temperature = 25,

$T1 = 25 + 7 = 32$; $T2 = 25 - 3 = 22$; $T3 = 25 - 7 = 18$

The operation mode chart for this example is as shown in below figure and the operation mode to be performed will depend on indoor intake air temperature and outdoor air temperature at the time when the judgment is made.

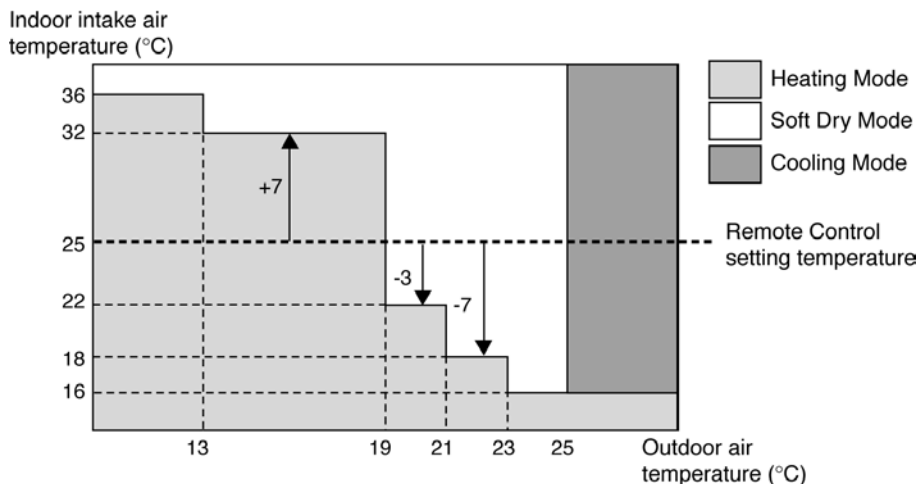

8.1.6. Indoor Fan Motor Operation

A. Basic Rotation Speed (rpm)

- Required rotation speed for fan is set to respond to the remote control setting (10 rpm unit)

[Cooling, Dry, Fan]

Remote Control	—	—	O	O	O	O	O	—	—	—
Tab (rpm)	PSHI	SHI	Hi	Me+	Me	Me-	Lo	Lo-	SLo	SSLo
E15D	600	560	560	495	480	425	400	370	310	200
E18D	680	640	590	563	510	488	430	410	350	200
E21D	800	750	700	660	600	560	510	480	410	200

[Heating]

Remote Control	—	—	O	O	O	O	O	—	—	—
Tab (rpm)	PSHi	SSHi	SHi	Me+	Me	Me-	Lo	Lo-	SLo	SSLo
E15D	650	610	600	545	540	495	480	440	300	200
E18D	740	690	640	618	560	553	490	490	320	200
E21D	870	820	770	745	670	655	580	570	370	200

B. Indoor Fan Control

i. Indoor fan control operation outline

1. Cooling / Dry

		Cooling	Dry	Ionizer	
Forced Operation		Hi	—	—	
Other than above	Min. control	Automatic operation mode judgement			
	Other than above	Freeze proofing		Lo-	
		With dew		Designated air flow shift	Designated air flow shift
	Operation	Automatic operation		Lo	Usually, automatic
		Manual Operation	Powerful	Setting +2UP	SLo
			Quiet	Setting -1down	SLo
	Other than the above	Other than the above	Remote control setup	Remote control setup	
	Other than the above	Automatic Operation	Powerful	Powerful automatic	SLo
			Quiet	Quiet automatic	SLo
		Other than the above	Usually, automatic	SLo	Usually, automatic
	Manual Operation	Powerful	Setting +2UP	SLo	—
		Quiet	Setting -1down	SLo	—
Other than the above		Remote control setup	SLo	Remote control setup	
MAX capability		SHi	—	—	

2. Heating

		Heating			
Forced Operation		SHi			
Min. control	Automatic operation mode judging		Lo-		
Other than above	During hot start		Stop		
	Under defrosting operation		Stop		
	Ability supply stop		Stop		
	Low-temperature capability measurement		SSH <i>i</i>		
	MAX control	Heating starting force operation		A stop, SLo	
		Ability supply stop		Lo-	
		Thermostat-off sampling		Specification	
		Piping temperature control		min Restrictions of fan speed by indoor pipe temperature	
	Min control	Fan speed minimum restrictions by indoor piping temperature		Me	
		Fan speed automatic minimum		Auto Fan Speed min Control	
	Other than above	Preparation operation start timer.	Fan speed automatic		Lo
			Manual Operation	Powerful	Setting +2UP
				Quiet	Setting -1down
				Other than the above	Remote control setup
Other than above		Fan speed shift control		Heating Fan Speed Control	
		Fan speed automatic	Powerful	Pipe temperature control +2UP	
			Quiet	Pipe temperature control -1down	
			Other than the above	Piping temperature control	
		Fan speed manual	Powerful	Setting +2UP	
			Quiet	Setting -1down	
			Other than the above	Remote control setup	

ii. Auto Fan Speed

1. Cooling

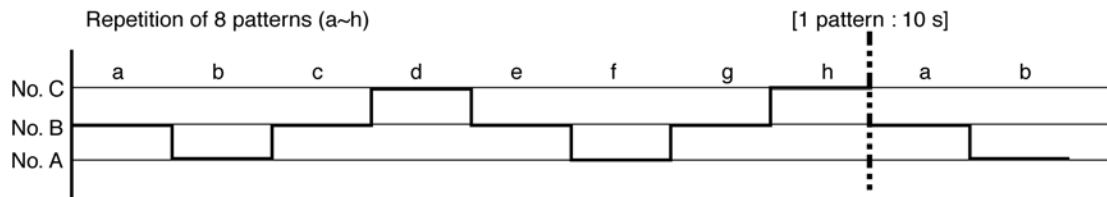

	Model	No. A	No. B	No. C
Powerful Program	E15D	540	560	580
	E18D	605	625	645
	E21D	690	710	730
Normal Program	E15D	480	500	520
	E18D	545	565	585
	E21D	630	650	670
Quiet Program	E15D	460	480	500
	E18D	525	545	565
	E21D	610	630	650

2. Heating

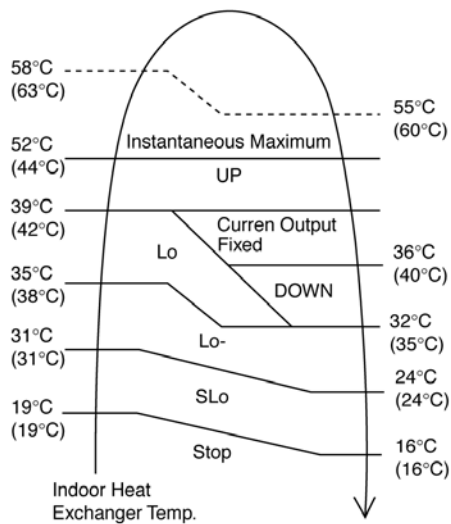

Note:

a. UP:

- If move from Lo, the fan speed will be shifted to Maximum 1520 rpm.
- If move from Maximum, the fan speed no change.
- In up zone, 10 rpm is added for every 10s until Maximum 1520 rpm.

b. DOWN:

- The fan speed will be decreased one step every 10 sec. until Minimum 1270 rpm.

c. Current Output Fixed:

- Maintain at present fan speed.

d. Instantaneous Maximum:

- Fan speed will be increased to maximum auto fan speed.

e. Temperature in () is for Powerful Mode operation.

C. Fan Motor Control

1. Motor specification

High voltage PWM Motor

2. Feedback Control

a. Number-of-rotations feedback

Immediately after the fan started, rpm is checked and duty is added, and feedback control is performed. For high voltage PWM motor, it is done once every 0.5 second.

b. Offset duty T max/min limit

High voltage PWM motor has maximum offset duty.
(Refer Indoor fan motor control basic rotation speed)

3. Abnormal Detection Control

Conditions:

- Out of rhythm signal input
- If feedback number of rotations exceeded #2550 r/min or when less than #50 r/min.

Control: Fans stop

Return: Restart after 5 seconds

* It will not detect the out of rhythm condition within 5s for phase control motor (PWM motor is when duty=0) after start.

A fan stops when condition (1) and (2) happen within 25.0 seconds after fan starting, and if this happens for continuously 7 times, it will not retry.

→ FM lock processing

4. Restart Prohibition Control

Restart is prohibited within 5s for phase control motor (PWM motor is when duty=0) after fan stop (except re-ON the power supply).

D. Deodorizing Control

i. Control condition

Control at cooling/dry operation and auto fan speed.

No Deodorizing Control is performed during ON timer standby operation and during Anti-freezing control prevention.

ii. Operation

The odor status is arranged as below and it is shifted as follow.

- * When COMP is ON 1 → 2 → 3
(Shift to 4 when COMP is OFF)
- * When COMP is OFF 4 → 5 → 6 → 7 → 6 ↔ 7
(Shift to 1 when COMP is ON)
- * Start from 4 if the Thermostat is OFF during the start operation.

Odor Status		1	2	3	4	5	6	7	6.7.6...	1
Status Shift according to COMP		ON			OFF					ON
Status Shift according to time (s)	Cooling zone	40	50	—	30	90	20	90	20.90.20...	ON
	Dry zone									
Fan Speed	Cooling zone	OFF	SSLo	Auto Fan Speed	SSLo	OFF	SSLo	OFF	SSLo.OFF...	
	Dry zone			SLo						

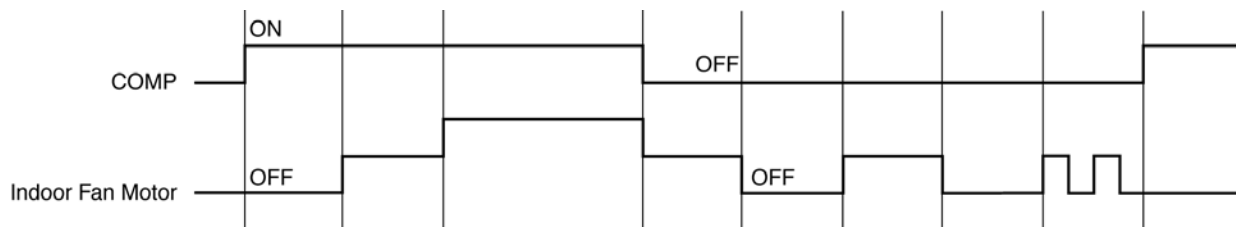

※ During FM OFF state, auto judgement will cause the FM to ON.

8.1.7. Outdoor Fan Motor Operation

Outdoor fan motor is operated with 15 fan speed. It starts when compressor starts operation and it stops 30 seconds after compressor stops operation for speed no.8.

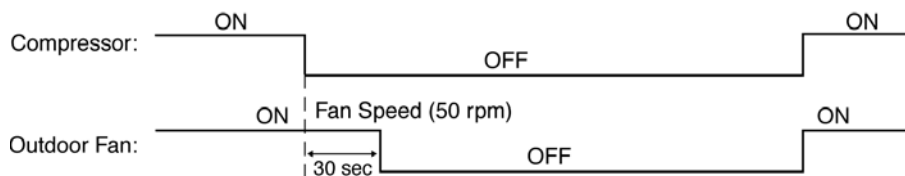

No.	RPM during Fan Speed (rpm)		
	E21D	E18D	E15D
15	75	73	71
14	75	73	71
13	70	68	66
12	68	66	64
11	64	62	60
10	62	60	60
9	58	58	58
8	50	50	50
7	45	45	45
6	40	40	40
5	35	35	35
4	30	30	30
3	25	25	25
2	20	20	20
1	15	15	15

8.1.8. Airflow Direction

1. There are one types of airflow, vertical airflow (directed by horizontal vane).
2. Control of airflow direction can be automatic (angles of direction is determined by operation mode, heat exchanger temperature and intake air temperature) and manual (angles of direction can be adjusted using remote control).

8.1.8.1. Vertical Airflow

Operation Mode	Airflow Direction		Vane Angle (°)					
			1	2	3	4	5	
Heating	Auto with Heat Exchanger Temperature	A	Downward fix	70				
		B	Downward fix	70				
		C	Upward fix	20				
		D	Upward fix	20				
	Manual		20	-	-	-	70	
Cooling, Soft Dry and Ion	Auto		20 ~ 70					
	Manual		20	-	-	-	70	

1. Automatic vertical airflow direction can be set using remote control; the vane swings up and down within the angles as stated above. For heating mode operation, the angle of the vane depends on the indoor heat exchanger temperature as Figure 1 below. When the air conditioner is stopped using remote control, the vane will shift to close position.

2. Manual vertical airflow direction can be set using remote control; the angles of the vane are as stated above and the positions of the vane are as Figure 2 below. When the air conditioner is stopped using remote control, the vane will shift to close position.

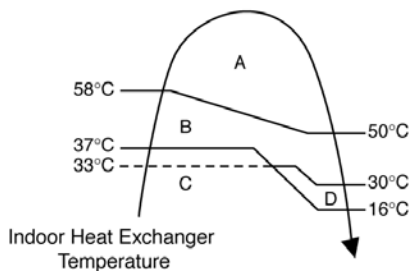

Figure 1

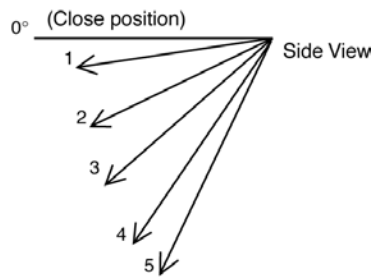

Figure 2

8.1.9. Quiet operation (Cooling Mode/Cooling area of Dry Mode)

A. Purpose

To provide quiet cooling operation compare to normal operation.

B. Control condition

a. Quiet operation start condition

- When “quiet” button at remote control is pressed.
Quiet LED illuminates.

b. Quiet operation stop condition

1. When one of the following conditions is satisfied, quiet operation stops:

- a. Powerful button is pressed.
- b. Stop by OFF/ON switch.
- c. Timer “off” activates.
- d. Quiet button is pressed again.

2. When quiet operation is stopped, operation is shifted to normal operation with previous setting.

3. When fan speed is changed, quiet operation is shifted to quiet operation of the new fan speed.

4. When operation mode is changed, quiet operation is shifted to quiet operation of the new mode.

5. During quiet operation, if timer “on” activates, quiet operation maintains.

6. After off, when on back, quiet operation is not memorised.

C. Control contents

1. Fan speed is changed from normal setting to quiet setting of respective fan speed.
This is to reduce sound of Hi, Me, Lo for 3dB.
2. Fan speed for quiet operation is -1 step from setting fan speed.

8.1.9.1. Quiet operation (Heating)**A. Purpose**

To provide quiet heating operation compare to normal operation.

B. Control condition

a. Quiet operation start condition

- When “quiet” button at remote control is pressed.
Quiet LED illuminates.

b. Quiet operation stop condition

1. When one of the following conditions is satisfied, quiet operation stops:
 - a. Powerful button is pressed.
 - b. Stop by OFF/ON switch.
 - c. Timer “off” activates.
 - d. Quiet button is pressed again.
2. When quiet operation is stopped, operation is shifted to normal operation with previous setting.
3. When fan speed is changed, quiet operation is shifted to quiet operation of the new fan speed.
4. When operation mode is changed, quiet operation is shifted to quiet operation of the new mode, except fan only mode.
5. During quiet operation, if timer “on” activates, quiet operation maintains.
6. After off, when on back, quiet operation is not memorised.

C. Control contents

a. Fan Speed manual

1. Fan speed is changed from normal setting to quiet setting of respective fan speed.
This is to reduce sound of Hi, Me, Lo for 3dB.
2. Fan speed for quiet operation is -1 step from setting fan speed.
3. Fan Speed Auto
Indoor FM RPM depends on pipe temp sensor of indoor heat exchanger.

8.1.10. Powerful Mode Operation

When the powerful mode is selected, the internal setting temperature will shift to achieve the setting temperature quickly.

(a) Cooling Operation

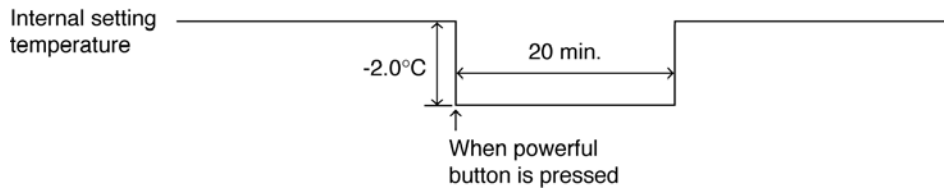

(b) Soft Dry Operation

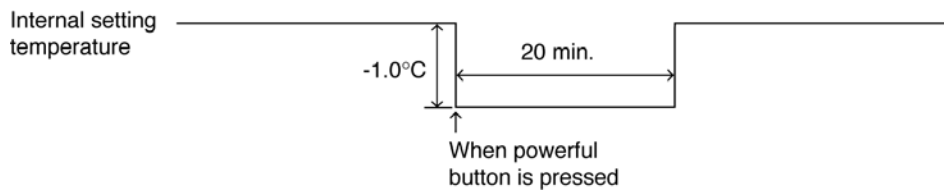

(c) Heating Operation

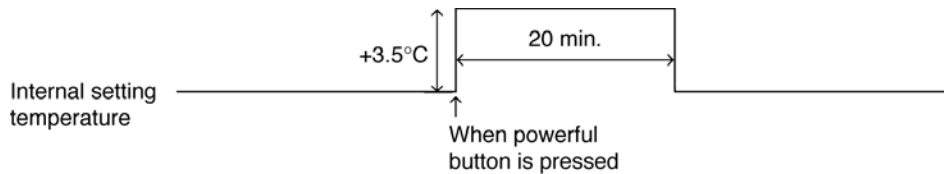

8.1.11. 24-Hour Real Time Timer Control

ON Timer

ON timer can be set using remote control, the unit with timer set will start operate earlier than the setting time. This is to provide a comfortable environment when reaching the set ON time.

Outdoor fan-ON instructions are transmitted to outdoor unit 60 minutes before setting time, then sampling the outdoor / indoor temperature with indoor fan at Lo- for 30 seconds. After detecting the indoor/outdoor temperature, the unit determines the operation starting time according to the load. However, when outdoor unit is operating, the preparation starting time will be set to minimum.

OFF Timer

When the OFF timer is set by using the remote control, the unit stop operate according to the desired setting.

Notes:

1. By pressing ON/OFF operation button, the ON Timer/OFF Timer setting will not be cancelled.
2. To cancel the previous timer setting, press CANCEL button.
3. To activate the previous timer setting, press SET button.
4. If main power supply is switched off, the Timer setting will be cancelled.

8.1.12. Auto Restart Control

1. When the power supply is cut off during the operation of air conditioner, the compressor will re-operate within three to four minutes (there are 10 patterns between 2 minutes 58 seconds and 3 minutes 52 seconds to be selected randomly) after power supply resumes.
2. This type of control is not applicable during ON/OFF Timer setting.

8.1.13. Indication Panel

LED	POWER	TIMER	QUIET	POWERFUL	AIR SWING
Color	Green	Orange	Orange	Orange	Orange
Light ON	Operation ON	Timer Setting ON	Quiet Mode ON	Powerful Mode ON	Auto Air Swing ON
Light OFF	Operation OFF	Timer Setting OFF	Quiet Mode OFF	Powerful Mode OFF	Auto Air Swing OFF

Note:

- If POWER LED is blinking, the possible operations of the unit are Hot Start, during Deice operation, operation mode judgment, or delay ON timer sampling.
- If Timer LED is blinking, there is an abnormality operation occurs.

8.1.14. Drain Pump Control Operation

- To drain out the condensed water trapped in the drain pan in order to prevent the condensed water from overflowing from the drain pan and leaking.

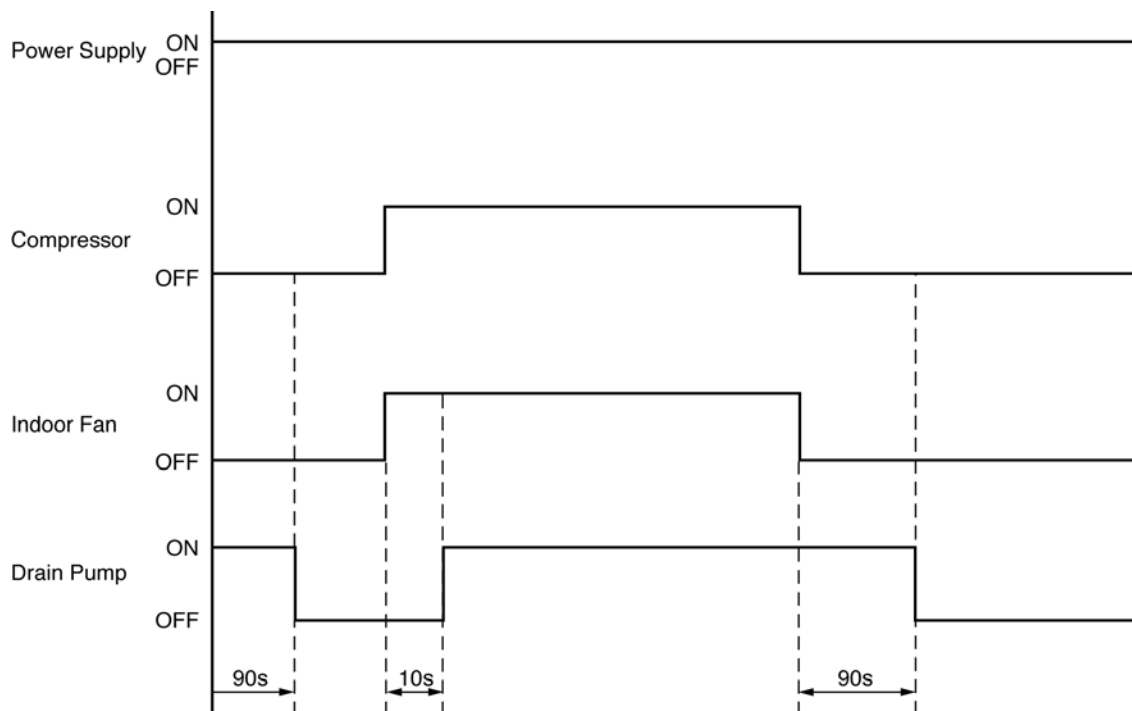

- Drain Pump starts to operate 10 sec. after compressor and Indoor fan ON.
- Drain Pump stop to operate 90 sec. after compressor OFF.

Drain Pump Error

Drain Pump Error occurs when:

- Within 20 minutes, the float switch is ON twice.
- Float switch is ON continuously for 2 minutes 30 seconds.

When error occurs, the timer indicator blinks and the unit stops its operation.

8.2. Protection Control Features

8.2.1. Protection Control For All Operations

8.2.1.1. Time Delay Safety Control

1. The compressor will not start for three minutes after stop of operation.
2. This control is not applicable if the power supply is cut off for 20 seconds and on again or after 4-way valve deices condition.

8.2.1.2. 30 Seconds Forced Operation

1. Once the compressor starts operation, it will not stop its operation for 30 seconds.
2. However, it can be stopped using remote control or Auto Switch at indoor unit.

8.2.1.3. Total Running Current Control

1. When the outdoor unit total running current (AC) exceeds X value, the frequency instructed for compressor operation will be decreased.
2. If the running current does not exceed X value for five seconds, the frequency instructed will be increased.
3. However, if total outdoor unit running current exceeds Y value, compressor will be stopped immediately for 2 minutes.

Model	E15D		E18D		E21D	
Operation Mode	X (A)	Y (A)	X (A)	Y (A)	X (A)	Y (A)
Cooling/Soft Dry (A)	7.20	17	8.74	17	11.02	17
Cooling/Soft Dry (B) & (C)	6.30	17	7.70	17	9.59	17
Heating	8.60	17	10.71	17	11.53	17

4. The first 30 minutes of cooling operation, (A) will be applied.

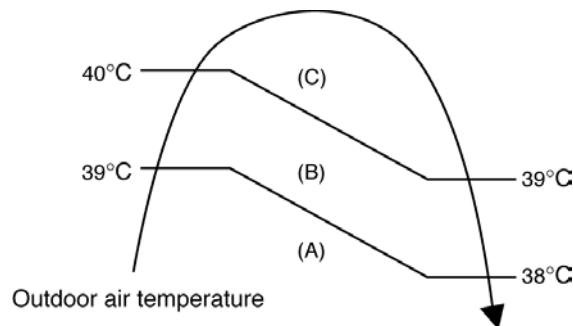

8.2.1.4. IPM (Power transistor) Prevention Control

A. Overheating Prevention Control

1. When the IPM temperature rises to 100°C, compressor operation will stop immediately.
2. Compressor operation restarts after three minutes the temperature decreases to 95°C.

B. DC Peak Current Control

1. When electric current to IPM exceeds set value of 22.33 A, the compressor will stop operate. Then, operation will restart after three minutes.
2. If the set value is exceeded again more than 30 seconds after the compressor starts, the operation will restart after 1 minute.
3. If the set value is exceeded again within 30 seconds after the compressor starts, the operation will restart after one minute. If this condition repeats continuously for seven times, all indoor and outdoor relays will be cut off.

8.2.1.5. Compressor Overheating Prevention Control

Instructed frequency for compressor operation will be regulated by compressor discharge temperature. The changes of frequency are as below figure.

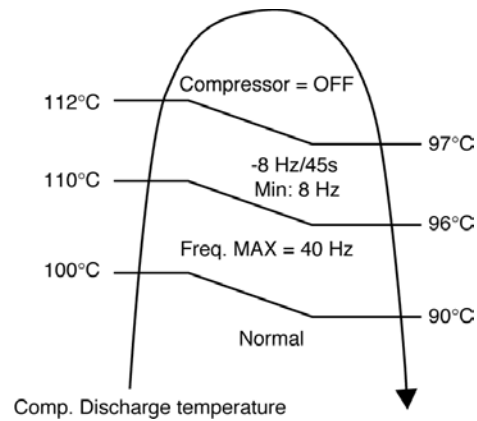

8.2.1.6. Low Pressure Prevention Control (Gas Leakage Detection)

a. Control start conditions

Control will perform when (1) - (3) condition continues operation for 5 minute and (4) is fulfill.

1. During cooling and dry operation: Frequency more than normal F_{cmax} 78 Hz (E15D), 86 Hz (E18D), 102 Hz (E21D).

During heating operation: Frequency more than normal F_h 71 Hz (E15D), 86 Hz (E18D), 92 Hz (E21D).

2. Outdoor total current I cooling: $I_b \leq I_c$

Heating: $I_b \leq I_c$

$I_c = I_a = 1.65$ A

$I_b = 0.65$ A

3. It is not during deice operation.

4. During cooling and dry operation: indoor suction-indoor piping temperature is below 4°C.

During of heating operation: Indoor piping temperature-indoor suction is under 5°C.

Control contents:

- compressor stops (restart after 3 minutes)
- if happen 2 times within (20 minutes), perform the following operation
 - 1) Unit stop operation
 - 2) Timer LED blink and "F91" indicated

8.2.1.7. Low Frequency Protection Control 1

When the compressor operate at frequency lower than 25 Hz continued for 20 minutes, the operation frequency will be increased to 24 Hz for two minutes.

8.2.1.8. Low Frequency Protection Control 2

When all the below conditions occur, minimum value (Freq. MIN) for the frequency instructed to compressor will change to 30 Hz for cooling mode operation and 20 Hz for heating mode operation.

Temperature, T, for:	Cooling/Soft Dry	Heating
Indoor intake air (°C)	$T < 14$ or $T \geq 30$	$T < 14$ or $T \geq 28$
Outdoor air (°C)	$T < 13$ or $T \geq 38$	$T < 4$ or $T \geq 24$
Indoor heat exchanger (°C)	$T < 30$	$T \geq 0$

8.2.2. Protection Control For Cooling & Soft Dry Operation

8.2.2.1. Outdoor Air Temperature Control

The compressor operating frequency is regulated in accordance to the outdoor air temperature as shown in the diagram below. This control will begin one minute after the compressor starts.

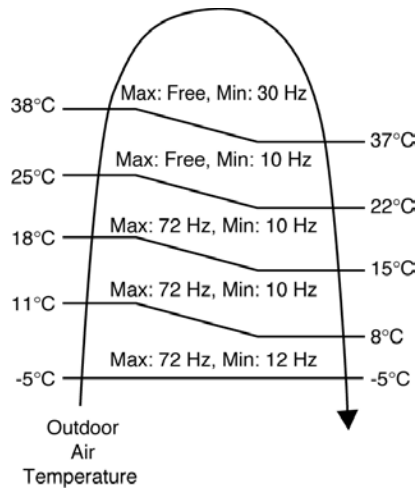

8.2.2.2. Cooling Overload Control

i. Pipe temperature limitation/restriction

- Detects the Outdoor pipe temperature and carry out below restriction/limitation (Limit the compressor Operation frequency)
- The compressor stop if outdoor pipe temperature exceeds 63°C
- If the compressor stops 4 times in 20 minutes, Timer LED blinking (F95: outdoor high pressure rise protection)

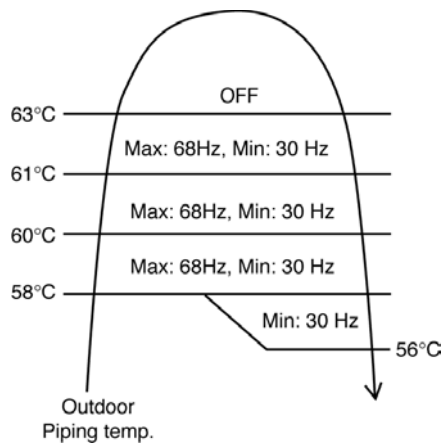

ii. Electrical part temperature rise protection control

1. Purpose

To prevent electronic components temperature rise during cooling overload.

2. Judgement Conditions

a) Outdoor temperature

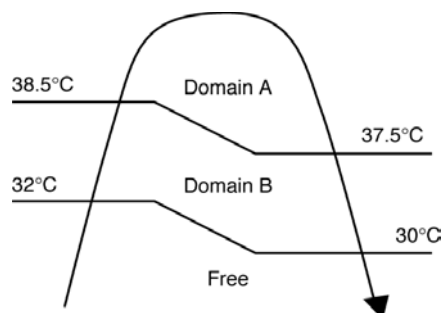

b) Outdoor total current above 5 A.

3. Control contents

In the outdoor fan speed no.

- i) In protectorate Domain A is referred to as min 660 rpm.
- ii) In protectorate Domain B, it is referred to as min 600 rpm.

4. Condition resolute

It is canceled when it stops satisfying all of the above-mentioned.

8.2.2.3. Anti-Freezing Control

1. When indoor heat exchanger temperature is lower than 7°C continuously for six minutes, compressor will stop operating.
2. Compressor will resume its operation three minutes after the indoor heat exchanger is higher than 13°C.
3. At the same time, indoor fan speed increase +20 rpm compared to its normal operation.
4. If indoor heat exchanger temperature is higher than 13°C for five minutes, the fan speed will return to its normal operation.

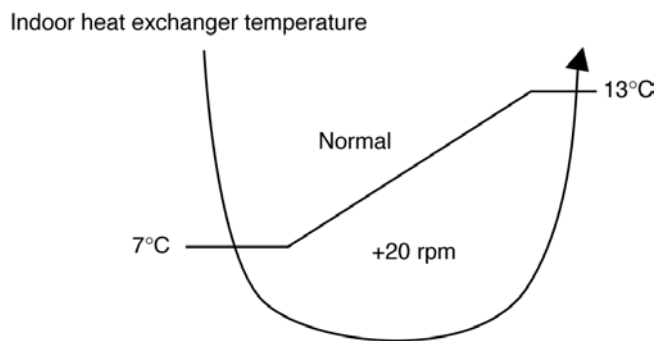

8.2.2.4. Anti-Dew Formation Control

a. Purpose

To prevent dew.

b. Control start conditions

When indoor are ceiling floor, duct and mini casette.

c. Control contents

Hz control is carried out according to the spray prevention status transmitted from indoor.

Spray prevention status(transmitted indoor)	Control contents	
	Relative control domain	MAX domain
0 (it usually controls)	Usually, control	Usually, control
1 (rise)	Relative change control priority	On tap up/10 seconds
2 (changeless)	Changeless	Changeless
3 (down)	-2 Hz/10 seconds	-2 Hz/10 seconds

Change is once to 10 seconds.

* Once the standup went into the down domain by Fcmax as for the Fcmax domain, it shifts to relative change control domain.

When the higher rank of relative control has this control and the status signal of 2-3 has come out.

Relative change control is stopped and follows directions of spray control.

Priority is given to the which is larger when freeze prevention down status and spray prevention down status are transmitted simultaneously.

In the case of spray status ≠0, it is referred to as maxFc.

8.2.3. Protection Control For Heating Operation

8.2.3.1. Intake Air Temperature Control

Compressor will operate at Max freq 94 (E15D), 128 (E18D, E21D) Hz if either one of the below conditions occur:

1. When the indoor intake air temperature is less than 21°C and remote control setting fan speed is lower Me-.
2. When the indoor intake air temperature is 35°C or above.

8.2.3.2. Outdoor Air Temperature Control

The Max current value is regulated in accordance to the outdoor air temperature as shown in the below figures.

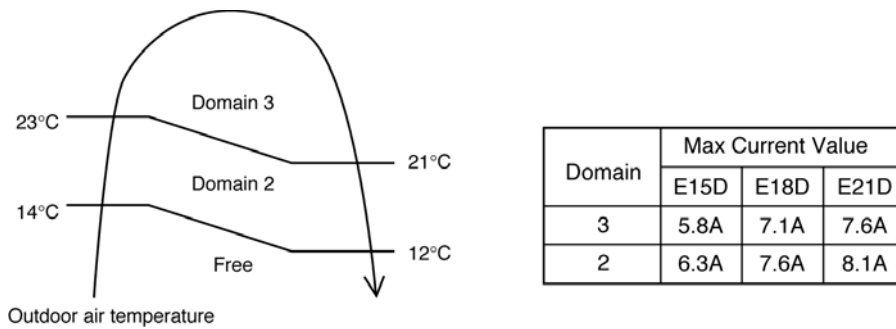

8.2.3.3. Overload Protection Control

The compressor operating frequency is regulated in accordance to indoor heat exchanger temperature as shown in below figures.

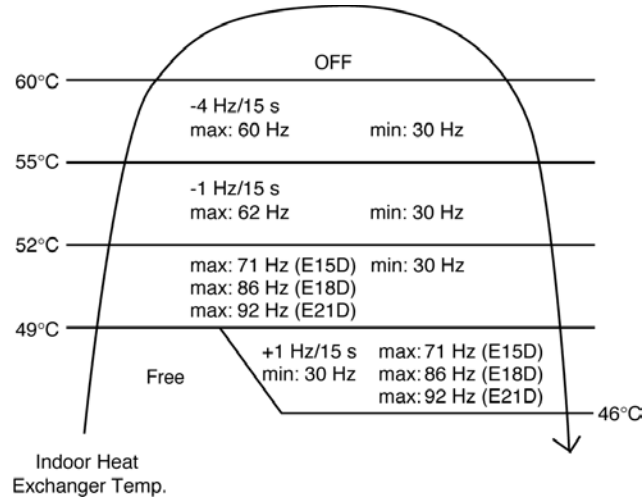

8.2.3.4. Deice Control

- Deice starts to prevent frosting at outdoor heat exchanger.
- Deice operation detection commences after minimum 60 minutes of Heating Operation.
- The outdoor heat exchanger temperature drops below 3°C for long period (minimum 40 minutes) during compressor is in operation, the deice operation may starts.

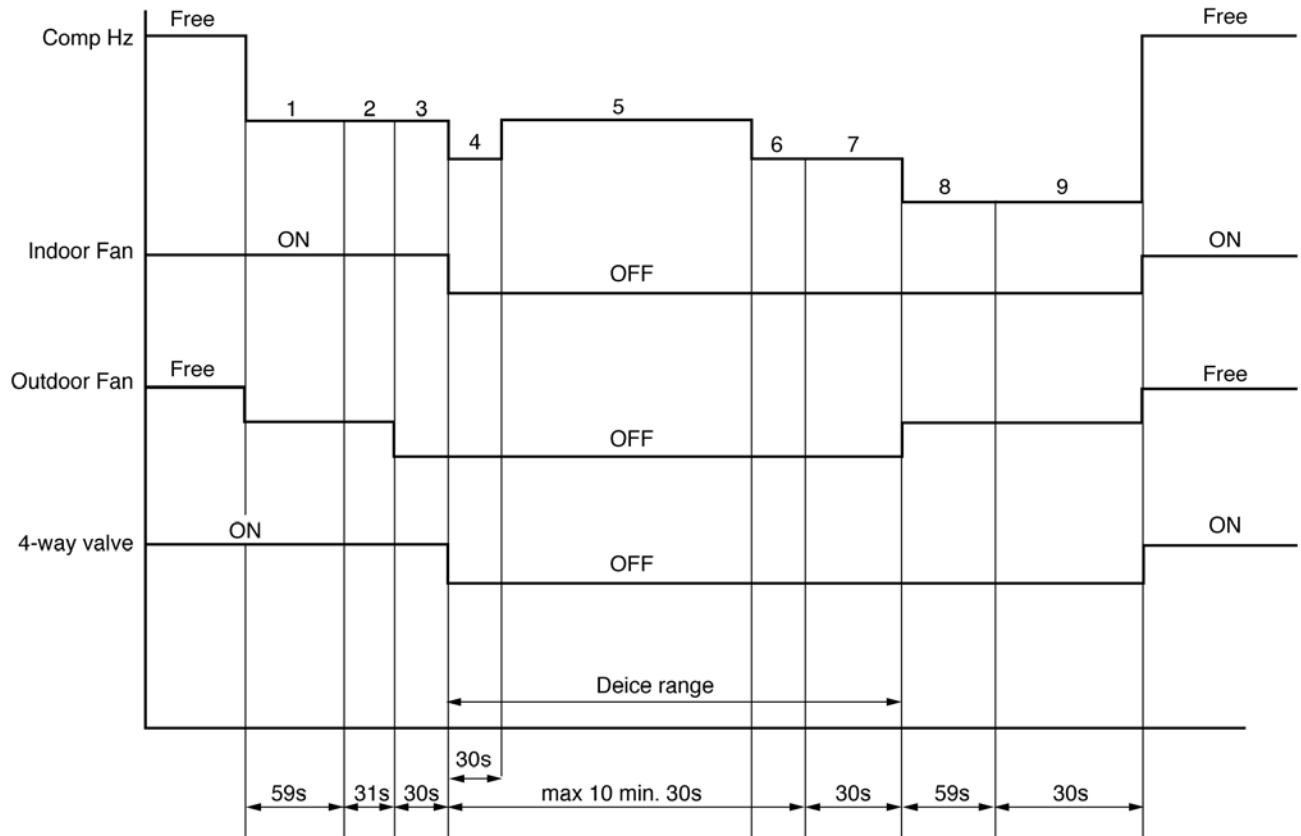

9 Operating Instructions

■ Definition

To prevent personal injury, injury to others and property damage, the following instructions must be followed.

Incorrect operation due to failure to follow instructions will cause harm or damage, the seriousness of which is classified as below:



Warning

This sign warns of death or serious injury.



Caution

This sign warns of injury or damage to property.

The instructions to be followed are classified by the following symbols:



This symbol denotes an action that is PROHIBITED.



These symbols denote actions that are COMPULSORY.

Thank you for purchasing Panasonic Air Conditioner

SAFETY PRECAUTIONS

Installation Precautions



Warning

Do not install, remove and reinstall the unit by yourself.

- Improper installation will cause leakage, electric shock or fire. Please consult an authorized dealer or specialist for the installation work.



Caution

- This air conditioner must be earthed. Improper grounding will cause electric shock.
- Ensure that the drainage piping is connected properly. Otherwise, water will leak.
- Current leakage protection equipment must be installed. Otherwise, electric shock or fire may occur.
- Do not install the unit in a potentially explosive atmosphere.

Operation Precautions



Warning

- Do not share power outlet.
- Do not modify power cord.
- Do not use an extension cord.
- Do not operate with wet hands.
- Do not insert finger or other objects into the indoor or outdoor unit.
- Do not attempt to repair the unit by yourself.
- Do not use rechargeable (Ni-Cd) batteries.
- Keep the remote control away from infants and small children to prevent them from accidentally swallowing the batteries.
- Use specified supply cord.
- If the supply cord is damaged or needed to be replaced, it must be replaced by the manufacturer or its service agent or a similarly qualified person in order to avoid a hazard.
- Remove the batteries if the unit is not going to be used for a long period of time.
- New batteries of the same type must be inserted following the polarity stated to prevent malfunction of the remote control.
- In case of emergency or abnormal condition (burnt smell, etc) occurs, turn off the power supply.



Caution

- Do not wash the unit with water, benzene, thinner or scouring powder.
- Do not use for other purposes such as preservation of food.
- Do not use any combustible equipment at airflow direction.
- Do not sit or place anything on the indoor or outdoor unit.
- Do not expose directly to cold air for a long period.
- Ventilate the room regularly.
- Pay attention as to whether the installation rack is damaged after long period of usage.
- Switch off the power supply before cleaning or servicing.
- Turn off the power supply if the unit is not used for a long period of time.

Safety Regulation

The appliance is not intended for use by young children or infirm person without supervision. Young children should be supervised to ensure that they do not play with the appliance.

Operation Condition (°C)

Use this air conditioner under the following temperature range.

DBT: Dry Bulb Temperature WBT: Wet Bulb Temperature	Indoor		Outdoor	
	DBT	WBT	DBT	WBT
Maximum Temperature (COOL)	32	23	43	26
Maximum Temperature (HEAT)	30	-	24	18
Minimum Temperature (COOL)	16	11	16	11
Minimum Temperature (HEAT)	16	-	-5	-6

Note: The illustrations in this manual are for explanation purposes only and may differ from the actual unit. It is subjected to change without notice for future improvement.

PRODUCT OVERVIEW

Indoor Unit (DT-Series)

CS-E15DTEW, CS-E18DTEW, CS-E21DTEW

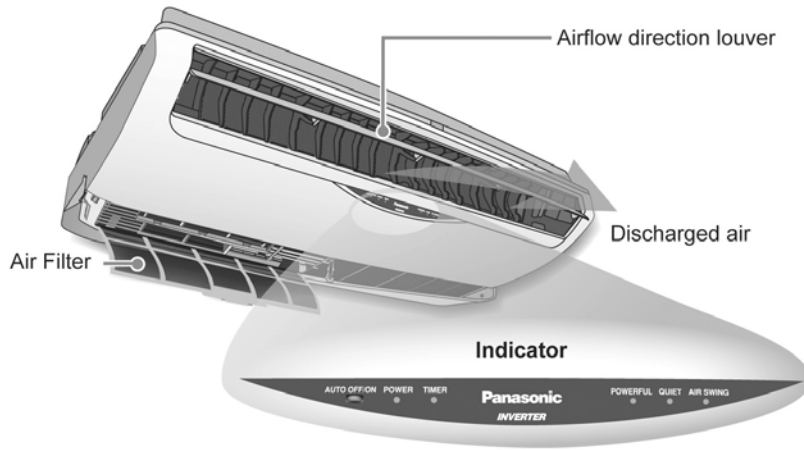

Indoor Unit (DD-Series)

CS-E15DD3EW, CS-E18DD3EW

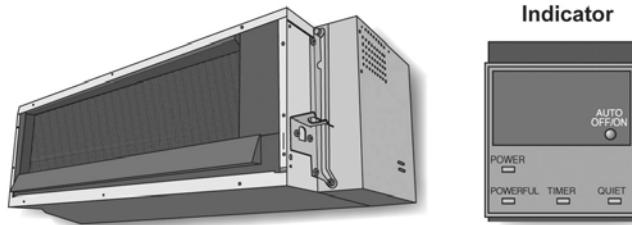

About

Indoor unit

CS-E15DTEW, CS-E18DTEW, CS-E21DTEW

- Auto Air Swing function optimise room comfort by giving finer control over the airflow direction.



CS-E15DD3EW, CS-E18DD3EW

- These units are mounted inside the ceiling. It uses external air intake vent and air outlet vent to operate.

Auto OFF/ON Button

- To operate the unit if the remote control is misplaced or malfunctioning.

Action	Operation mode
Press once.	Automatic Operation
Press until "beep" sound and release.	Cooling Operation
Press until "beep" sound and release. Press again until "beep-beep" sound and release.	Heating Operation

- To OFF, press again the Auto OFF/ON button.

Troubleshooting



- | | |
|----------------------------------------------------|----------------------------------------------------------------------------|
| ● Operation delayed for few minutes after restart. | ➤ This is a normal self protection control. |
| ● Sound like water flowing during operation. | ➤ Caused by refrigerant flow inside. |
| ● Mist emerges from indoor unit. | ➤ Condensation effect due to cooling process. |
| ● Noisy during operations. | ➤ Installation work could be slanted or front panel didn't close properly. |
| ● Cracking sound can be heard during operations. | ➤ Panel expanding/contracting due to the changes in temperature. |

■ About

Indoor unit

CS-E15DB4EW, CS-E18DB4EW, CS-E21DB4ES

- The air is discharged evenly through 4 output vents.



Auto OFF/ON Button

- To operate the unit if the remote control is misplaced or malfunctioning.

Action	Operation mode
Press once.	Automatic Operation
Press until "beep" sound and release.	Cooling Operation
Press until "beep" sound and release. Press again until "beep-beep" sound and release.	Heating Operation

- To OFF, press again the Auto OFF/ON button.

Remote Control Preparation

- Pull out

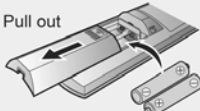

- Insert batteries (AAA or R03)

- Press CLOCK button



- Set current time

- Press again to confirm

- Timer operation will be based on current time set.
- The batteries can be used for approximately 1 year.
- The batteries must be recycled or disposed of properly.



Remote Control Signal

- Make sure it is not obstructed.
- Maximum distances : 8m.
- Certain fluorescent lights may interfere with signal transmission. Consult your dealer.

PRODUCT OVERVIEW

Indoor Unit (DB-Series)

CS-E15DB4EW, CS-E18DB4EW, CS-E21DB4ES

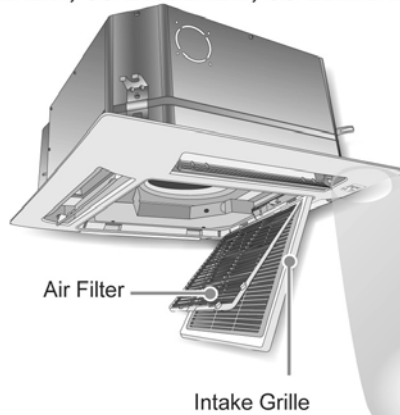

Indicator



Outdoor Unit

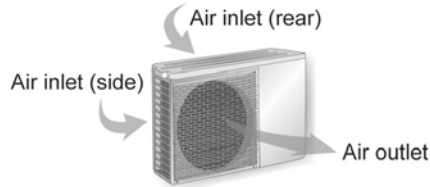

Remote Control

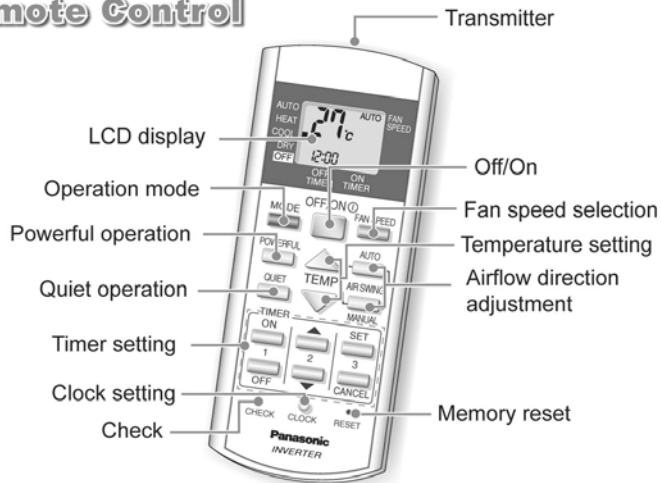

Troubleshooting



- Remote control/display does not work.
 - Check whether batteries are correctly inserted or need replacement.
- The unit cannot operate.
 - Check either circuit breaker is tripped or timer is used correctly.
 - Ensure "OFF" indicator does not shown on remote control.
- Outdoor unit emits water/steam.
 - Condensation or evaporation happens at piping surface.

HOW TO OPERATE

Auto, Heat, Cool, Dry

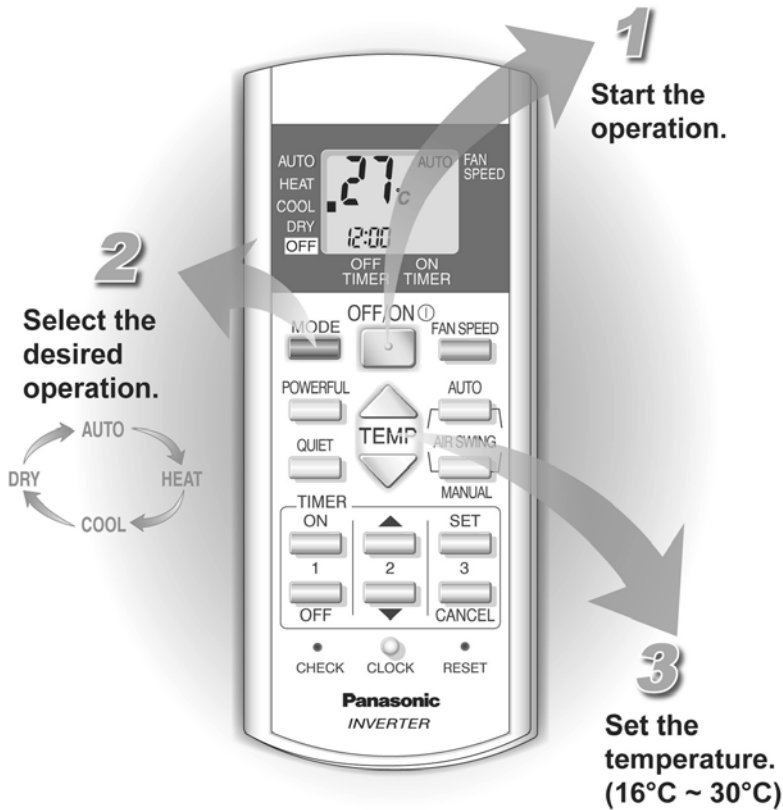

■ Operation Details

AUTO - Automatic Operation

- The unit will automatically select the operation mode according to the setting, outdoor and room temperature. During operation mode selection, power indicator blinks. For every 30 minutes, the operation mode is reselected.

HEAT - Heating Operation

- Enables you to enjoy the warming effect at your preferred setting temperature.
- For cold air prevention, air might not blow out immediately and power indicator blinks when operation starts.
- Also operates in defrost mode (maximum 12 minutes) where by the power indicator blinks. The melted frost is drained at outdoor unit and indoor fan is stopped.

COOL - Cooling Operation

- Enables you to enjoy the cooling effect at your preferred setting temperature.

DRY - Soft Dry Operation

- Enables you to set the desired temperature at low fan speed which provides you with dehumidifying surroundings.

- Powerful and Quiet operations can be activated in all operation modes.

- Press **OFF/ON** button again to stop the operation.



Hints

- To save electricity, close the curtains when using air conditioner to prevent sunlight and heat from coming in.
- Heat is obtain from outdoor air to warm up the room. Use an additional heater when the outdoor ambient temperature is low.



Troubleshooting

- The room has a peculiar odour.
 - This may be a damp smell emitted by the wall, carpet, furniture or clothing in the room.
- Air conditioner does not cool or heat efficiently.
 - Ensure the temperature has been set correctly.
 - Ensure windows and doors have been closed properly.
 - Ensure filters are cleaned or replaced when necessary.
 - Ensure inlet and outlet vents of the units have not been obstructed.

■ Operation Details

POWERFUL

- To achieve setting temperature quickly.

QUIET

- To provide a quiet environment.

FAN SPEED

- To provide you with various fan speed selections.
- There are 5 levels of fan speed in addition to automatic fan speed.
- Automatic fan speed: The speed of the indoor fan is automatically adjusted according to the operation.

AIR SWING - AUTO

- To ventilate air in the room.
- The vertical airflow direction louver swings up and down automatically.

AIR SWING - MANUAL

- The airflow direction can be adjusted as desired by using remote control.
- Please do not adjust the vertical airflow direction louver by hand.

For DT-series indoor unit only

- Horizontal airflow direction louver could be adjusted manually.

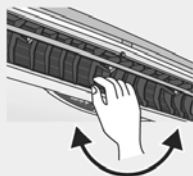

HOW TO OPERATE

Powerful, Quiet, Fan Speed, Air Swing

POWERFUL

Enables powerful operation.

FAN SPEED

Select fan speed.

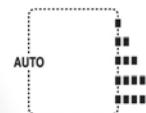

AUTO AIR SWING

Enables auto air swing.

MANUAL AIR SWING

Adjust the vertical airflow direction louver.

QUIET

Enables quiet operation.

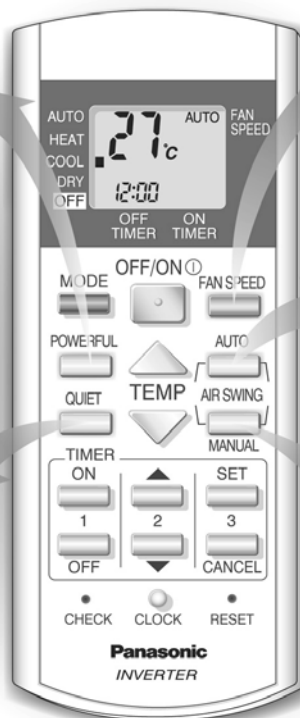

- Air Swing is not applicable for DD-series indoor unit.
- Powerful and Quiet operations could not be activated at the same time.
- Powerful and Quiet operations could be cancelled by pressing the respective button again.

Hints



- If you wish to have the cool air blowing directly on you, set the airflow direction downward but not for an excessive length of time, as it may harm your health.
- Approximately 10% of electricity can be saved if you set the temperature 1°C higher in cooling operation or 2°C lower in heating operation than the desired temperature.

Troubleshooting



- Indoor fan stops occasionally during Automatic Fan Speed setting. > This is an advanced feature that helps to remove smell from the surrounding area during operation.
- Indoor fan stops occasionally during heating operation. > To avoid unintended cooling effect.

HOW TO OPERATE

Timer

1

Select ON or OFF timer.

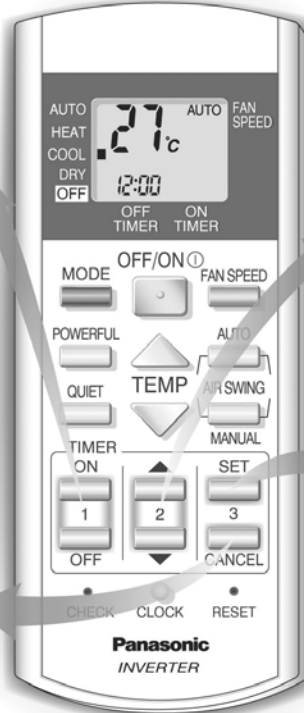

2



Set the desired time.

3

Confirm the setting.

CANCEL

Cancel the selected timer.

- Ensure the clock on the remote control has been set correctly.
- You could use the ON and OFF timers at the same time.
- To cancel either the ON or OFF timer, press  or , then press .

Operation Details

TIMER

- Use the ON timer to turn on the air conditioner at the desired time. This will give you a cooling or warming environment, e.g. when you return from work or wake up.
- When the ON timer is set, operation will start maximum 35 minutes earlier before the actual set time.
- Use the OFF timer to stop the air conditioner operation at the desired time. This can save electricity while you are going out or sleeping.
- The set timer will repeat daily once it is set.
- If there is a power failure, you can press the SET button to restore the previous setting once the power is resumed.
- If the timer is cancelled, you can restore the previous setting by pressing the SET button.

CHECK

- Where there is error, the unit stops its operation and timer indicator blinks.

1. Press for 5 seconds.



2. Browse for respective error code, where "beep" sounds are heard.
3. Turn off the power supply and call authorized distributor.

Note:

Press the "RESET" button to quit checking.
Unit might be operated with limited function depending on error found.
(Operation starts, 4 "beep" sounds are heard.)



Hint

- Press CLOCK more than 10 seconds to change the time format from 24 hours to AM/PM format.
- For your convenience, you could set the air conditioner to operate automatically by using both ON and OFF timer.



Troubleshooting

- TIMER indicator always on. ➤ Timer is activated and the setting will repeat itself daily.
- POWER indicator is blinking 35 minutes before ON timer is activated. ➤ The unit is determining the operation mode by sensing the room temperature. This happens when it has been set to AUTO operation mode.

■ Cleaning Instructions

- Do not use benzene, thinner or scouring powder.
- Use soaps or neutral household detergent (≈pH7) only.
- Do not use water with temperature higher than 40°C.

INDOOR UNIT

- Wipe the unit gently with a soft, dry cloth.

AIR FILTER

- It is recommended to clean the air filters once every 6 weeks.
- Purchase the replacement filter if it is damaged.
Part no.: CWD001088

■ Preparation for extended Non-operation

- Operate the unit for 2~3 hours using heating operation to dry the internal parts.
- Turn off the power supply.
- Remove the remote control batteries.

■ Pre-season Inspection

- This inspection is recommended before operating the air conditioner at every season.
- Check if the remote control batteries needed to be replaced.
- Ensure there is no obstruction at all air intake and outlet vents.
- After the start of operation for 15 minutes, it is normal if the temperature differences between air intake and outlet vents at indoor unit is:-

Operation	Temperature
Cooling	≥ 8°C
Heating	≥ 14°C

CARE & CLEANING



Switch off the power supply before cleaning

DT-series indoor unit

INDOOR UNIT

Wipe gently.

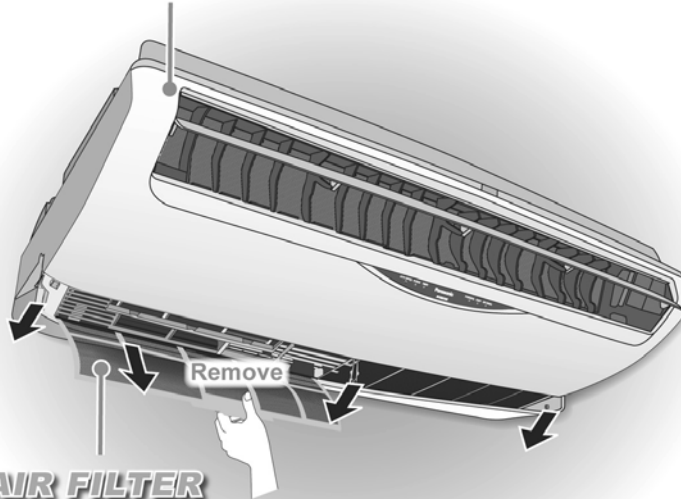

AIR FILTER

Vacuum, wash and dry.



Hints

- Clean the filter regularly as dirty filters will cause unpurified air, low cooling or heating capacity, unpleasant smells and higher energy consumption.
- The unit will become dirty and the performance of the unit will decrease after used for several seasons. Please consult an authorized dealer to perform seasonal inspections in addition to regular cleaning.
- This air conditioner is equipped with a built-in surge protective device. However, in order to further protect your air conditioner from being damaged by abnormally strong lightning activity, you may switch off the power supply.

CARE & CLEANING



**Switch off the power supply
before cleaning**

DB-series indoor unit



■ Cleaning Instructions

INDOOR UNIT

- Wipe the unit gently with a soft, dry cloth.

AIR FILTER

- It is recommended to clean the air filters once every 6 weeks.
- Purchase the replacement filter if it is damaged.
Part no.: CWD001142

■ Preparation for extended Non-operation

- Operate the unit for 2~3 hours using heating operation to dry the internal parts.
- Turn off the power supply.
- Remove the remote control batteries.

■ Pre-season Inspection

- This inspection is recommended before operating the air conditioner at every season.
- Check if the remote control batteries needed to be replaced.
- Ensure there is no obstruction at all air intake and outlet vents.
- After the start of operation for 15 minutes, it is normal if the temperature differences between air intake and outlet vents at indoor unit is:-

Operation	Temperature
Cooling	≥ 8°C
Heating	≥ 14°C



Hints

- Clean the filter regularly as dirty filters will cause unpurified air, low cooling or heating capacity, unpleasant smells and higher energy consumption.
- The unit will become dirty and the performance of the unit will decrease after used for several seasons. Please consult an authorized dealer to perform seasonal inspections in addition to regular cleaning.
- This air conditioner is equipped with a built-in surge protective device. However, in order to further protect your air conditioner from being damaged by abnormally strong lightning activity, you may switch off the power supply.

10 Installation And Servicing Air Conditioner Using R410A

10.1. Outline

10.1.1. About R410A Refrigerant

1. Converting air conditioners to R410A

Since it was declared in 1974 that chlorofluorocarbons (CFC), hydro chlorofluorocarbons (HCFC) and other substances pose a destructive danger to the ozone layer in the earth's upper stratosphere (20 to 40 km above the earth), measures have been taken around the world to prevent this destruction.

The R22 refrigerant which has conventionally been used in ACs is an HCFC refrigerant and, therefore, possesses this ozone-destroying potential. International regulations (the Montreal Protocol on Ozone-Damaging Substances) and the domestic laws of various countries call for the early substitution of R22 by a refrigerant which will not harm the ozone layer.

- In ACs, the HFC refrigerant which has become the mainstream alternative is called R410A. Compared with R22, the pressure of R410A is approximately 1.6 times as high at the same refrigerant temperature, but the energy efficiency is about the same. Consisting of hydrogen (H), fluorine (F) and carbon (C), R410A is an HFC refrigerant. Another typical HFC refrigerant is R407C. While the energy efficiency of R407C is somewhat inferior to that of R410A, it offers the advantage of having pressure characteristics which are about the same as those of R22, and is used mainly in packaged ACs.

2. The characteristics of HFC (R410A) refrigerants

a. Chemical characteristics

The chemical characteristics of R410A are similar to those of R22 in that both are chemically stable, non-flammable refrigerants with low toxicity.

However, just like R22, the specific gravity of R410A gas is heavier than that of air. Because of this, it can cause an oxygen deficiency if it leaks into a closed room since it collects in the lower area of the room. It also generates toxic gas when it is directly exposed to a flame, so it must be used in a well ventilated environment where it will not collect.

Table 1 Physical comparison of R410A and R22

	R410A	R22
Composition (wt%)	R32/R125 (50/50)	R22 (100)
Boiling point (°C)	-51.4	-40.8
Vaporizing pressure (25°C)	1.56 Mpa (15.9 kgf/cm ²)	0.94 Mpa (9.6 kgf/cm ²)
Saturated vapor density	64.0 kg/m ³	44.4 kg/m ³
Flammability	Non-flammable	Non-flammable
Ozone-destroying point (ODP)	0	0.055
Global-warming point (GWP)	1730	1700

b. Compositional change (pseudo-azeotropic characteristics)

R410A is a pseudo-azeotropic mixture comprising the two components R32 and R125. Multi-component refrigerants with these chemical characteristics exhibit little compositional change even from phase changes due to vaporization (or condensation), which means that there is little change in the circulating refrigerant composition even when the refrigerant leaks from the gaseous section of the piping.

Accordingly, R410A can be handled in almost the same manner as the single-component refrigerant R22. However, when charging, because there is a slight change in composition between the gas phase and the liquid phase inside a cylinder or other container, charging should basically begin with the liquid side.

c. Pressure characteristics

As seen in Table 2, the gas pressure of R410A is approximately 1.6 times as high as that of R22 at the same refrigerant temperature, which means that special R410A tools and materials with high-pressure specifications must be used for all refrigerant piping work and servicing.

Table 2 Comparison of R410A and R22 saturated vapor density

Refrigerant Temperature (°C)	Unit: MPa	
	R410A	R22
-20	0.30	0.14
0	0.70	0.40
20	1.35	0.81
40	2.32	1.43
60	3.73	2.33
65	4.15	2.60

d. R410A refrigerating machine oil

Conventionally, mineral oil or a synthetic oil such as alkylbenzene has been used for R22 refrigerating machine oil. Because of the poor compatibility between R410A and conventional oils like mineral oil, however, there is a tendency for the refrigerating machine oil to collect in the refrigerating cycle. For this reason, polyester and other synthetic oils which have a high compatibility with R410A are used as refrigerating machine oil.

Because of the high hygroscopic property of synthetic oil, more care must be taken in its handling than was necessary with conventional refrigerating machine oils. Also, these synthetic oils will degrade if mixed with mineral oil or alkylbenzene, causing clogging in capillary tubes or compressor malfunction. Do not mix them under any circumstances.

10.1.2. Safety Measures When Installing/Serviceing Refrigerant Piping

Cause the gas pressure of R410A is approximately 1.6 times as high as that of R22, a mistake in installation or servicing could result in a major accident. It is essential that you use R410A tools and materials, and that you observe the following precautions to ensure safety.

1. Do not use any refrigerant other than R410A in ACs that have been used with R410A.
2. If any refrigerant gas leaks while you are working, ventilate the room. Toxic gas may be generated if refrigerant gas is exposed to a direct flame.
3. When installing or transferring an AC, do not allow any air or substance other than R410A to mix into the refrigeration cycle. If it does, the pressure in the refrigeration cycle can become abnormally high, possibly causing an explosion and/or injury.
4. After finishing the installation, check to make sure there is no refrigerant gas leaking.
5. When installing or transferring an AC, follow the instructions in the installation instructions carefully. Incorrect installation can result in an abnormal refrigeration cycle or water leakage, electric shock, fire, etc.
6. Do not perform any alterations on the AC unit under any circumstances. Have all repair work done by a specialist. Incorrect repairs can result in a water leakage, electric shock, fire, etc.

10.2. Tools For Installing/Serviceing Refrigerant Piping

10.2.1. Necessary Tools

In order to prevent an R410A AC from mistakenly being charged with any other refrigerant, the diameter of the 3-way valve service port on the outdoor unit has been changed. Also, to increase its ability to withstand pressure, the opposing dimensions have been changed for the refrigerant pipe flaring size and flare nut. Accordingly, when installing or servicing refrigerant piping, you must have both the R410A and ordinary tools listed below.

Table 3 Tools for installation, transferring or replacement

Type of work	Ordinary tools	R410A tools
Flaring	Flaring tool (clutch type), pipe cutter, reamer	Copper pipe gauge for clearance Adjustment, flaring tool (clutch type)*1)
Bending, connecting pipes	Torque wrench (nominal diameter 1/4, 3/8, 1/2). Fixed spanner (opposing sides 12 mm, 17 mm, 19 mm). Adjustable wrench, Spring bender	
Air purging	Vacuum pump. Hexagonal wrench (opposing sides 4 mm)	Manifold gauge, charging hose, vacuum pump adaptor
Gas leak inspection	Gas leak inspection fluid or soapy water	Electric gas leak detector for HFC refrigerant*2)

*1) You can use the conventional (R22) flaring tool. If you need to buy a new tool, buy the R410A type.

*2) Use when it is necessary to detect small gas leaks.

For other installation work, you should have the usual tools, such as screwdrivers (+,-), a metal-cutting saw, an electrical drill, a hole core drill (65 or 70 dia.), a tape measure, a level, a thermometer, a clamp meter, an insulation tester, a voltmeter, etc.

Table 4 Tools for serving

Type of work	Ordinary tools	R410A tools
Refrigerant charging		Electronic scale for refrigerant charging. Refrigerant cylinder. Charging orifice and packing for refrigerant cylinder
Brazing (Replacing refrigerating cycle part*1)	Nitrogen blow set (be sure to use nitrogen blowing for all brazing), and brazing machine	

*1) Always replace the dryer of the outdoor unit at the same time. The replacement dryer is wrapped in a vacuum pack. Replace it last among the refrigerating cycle parts. Start brazing as soon as you have opened the vacuum pack, and begin the vacuuming operation within 2 hours.

10.2.2. R410A Tools

1. Copper tube gauge for clearance adjustment
(used when flaring with the conventional flaring tool (clutch type))

- This gauge makes it easy to set the clearance for the copper tube to 1.0-1.5 mm from the clamp bar of the flaring tool.

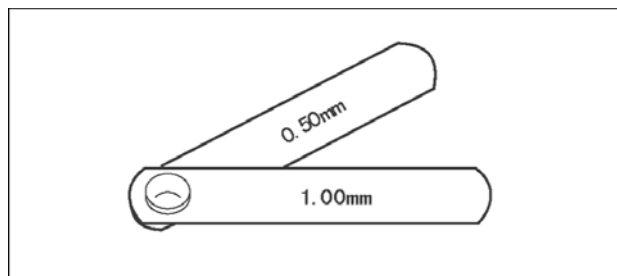

Fig. 1 Copper tube gauge for clearance adjustment

2. Flaring tool (clutch type)

- In the R410A flaring tool, the receiving hole for the clamp bar is enlarged so the clearance from the clamp bar can be set to 0-0.5 mm, and the spring inside the tool is strengthened to increase the strength of the pipe-expanding torque. This flaring tools can also be used with R22 piping, so we recommend that you select it if you are buying a new flaring tool.

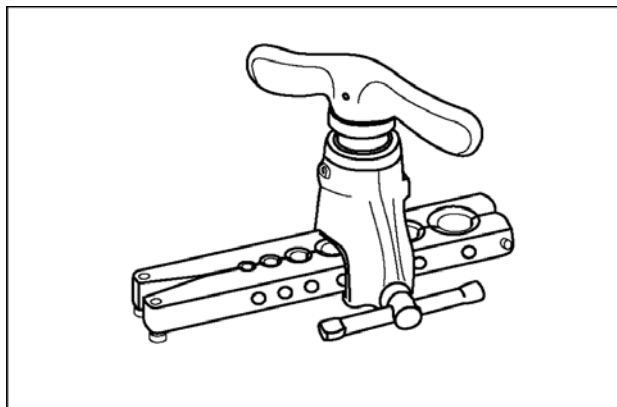

Fig. 2 Flaring tool (clutch type)

3. Torque wrenches

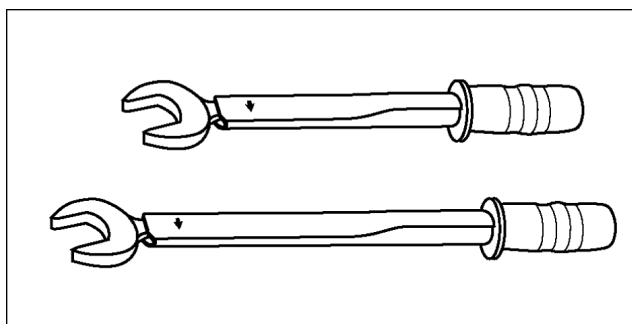

Fig. 3 Torque wrenches

Table 5

	Conventional wrenches	R410A wrenches
For 1/4 (opposite side x torque)	17 mm x 18 N.m (180 kgf.cm)	17 mm x 18 N.m (180 kgf.cm)
For 3/8 (opposite side x torque)	22 mm x 42 N.m (420 kgf.cm)	22 mm x 42 N.m (420 kgf.cm)
For 1/2 (opposite side x torque)	24 mm x 55 N.m (550 kgf.cm)	26 mm x 55 N.m (550 kgf.cm)

4. Manifold gauge

- Because the pressure is higher for the R410A type, the conventional type cannot be used.

Table 6 Difference between R410A and conventional high / low-pressure gauges

	Conventional gauges	R410A gauges
High-pressure gauge (red)	-76 cmHg - 35 kgf/cm ³	-0.1 - 5.3 Mpa -76 cmHg - 53 kgf/cm ³
Low-pressure gauge (blue)	-76 cmHg - 17 kgf/cm ³	-0.1 - 3.8 Mpa -76 cmHg - 38 kgf/cm ³

- The shape of the manifold ports has been changed to prevent the possibility of mistakenly charging with another type of refrigerant.

Table 7 Difference between R410A and conventional manifold port size

	Conventional gauges	R410A gauges
Port size	7/16 UNF 20 threads	1/2 UNF 20 threads

5. Charging hose

- The pressure resistance of the charging hose has been raised to match the higher pressure of R410A. The hose material has also been changed to suit HFC use, and the size of the fitting has been changed to match the manifold ports.

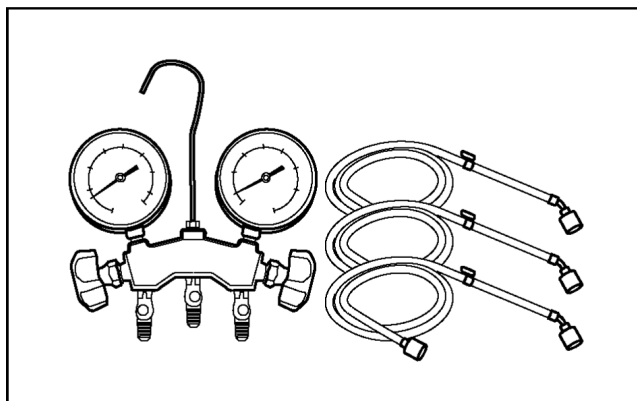

Fig. 4 Manifold gauge charging hose

Table 8 Difference between R410A and conventional charging hoses

		Conventional hoses	R410A hoses
Pressure resistance	Working pressure	3.4 MPa (35 kgf/cm ³)	5.1 MPa (52 kgf/cm ³)
	Bursting pressure	17.2 MPa (175 kgf/cm ³)	27.4 MPa (280 kgf/cm ³)
Material		NBR rubber	HNBR rubber Nylon coating inside

6. Vacuum pump adaptor

- When using a vacuum pump for R410A, it is necessary to install an electromagnetic valve to prevent the vacuum pump oil from flowing back into the charging hose. The vacuum pump adaptor is installed for that purpose. If the vacuum pump oil (mineral oil) becomes mixed with R410A, it will damage the unit.

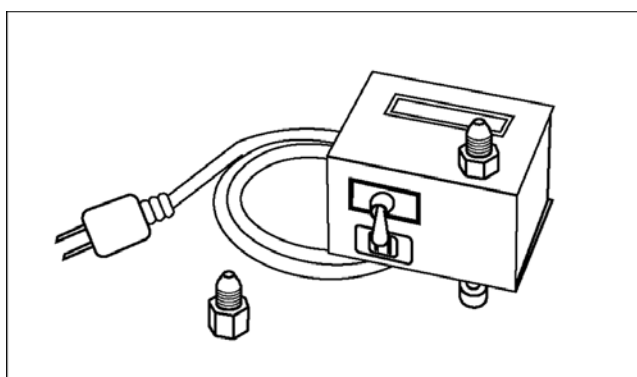

Fig. 5 Vacuum pump adaptor

7. Electric gas leak detector for HFC refrigerant

- The leak detector and halide torch that were used with CFC and HCFC cannot be used with R410A (because there is no chlorine in the refrigerant).
- The present R134a leak detector can be used, but the detection sensitivity will be lower (setting the sensitivity for R134a at 1, the level for R410A will drop to 0.6).
- For detecting small amounts of gas leakage, use the electric gas leak detector for HFC refrigerant. (Detection sensitivity with R410A is about 23 g/year).

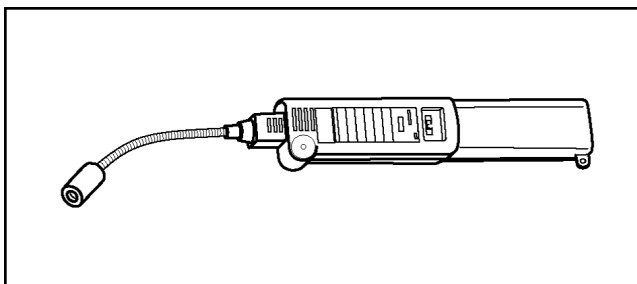

Fig. 6 Electric gas leak detector for HFC refrigerant

8. Electronic scale for refrigerant charging

- Because of the high pressure and fast vaporizing speed of R410A, the refrigerant cannot be held in a liquid phase inside the charging cylinder when charging is done using the charging cylinder method, causing bubbles to form in the measurement scale glass and making it difficult to see the reading. (Naturally, the conventional R22 charging cylinder cannot be used because of the differences in the pressure resistance, scale gradation, connecting port size, etc.)
- The electronic scale has been strengthened by using a structure in which the weight detector for the refrigerant cylinder is held by four supports. It is also equipped with two connection ports, one for R22 (7/16 UNF, 20 threads) and one for R410A (1/2 UNF, 20 threads), so it can also be used for conventional refrigerant charging.
- There are two types of electronic scales, one for 10-kg cylinders and one for 20-kg cylinders. (The 10-kg cylinder is recommended.)

Refrigerant charging is done manually by opening and closing the valve.

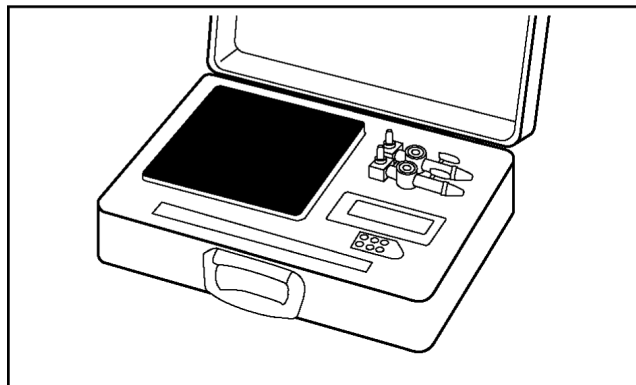

Fig. 7 Electronic scale for refrigerant charging

9. Refrigerant cylinders

- The R410A cylinders are labeled with the refrigerant name, and the coating color of the cylinder protector is pink, which is the color stipulated by ARI of the U.S.
- Cylinders equipped with a siphon tube are available to allow the cylinder to stand upright for liquid refrigerant charging.



Fig. 8 Refrigerant cylinders

10. Charging orifice and packing for refrigerant cylinders

- The charging orifice must match the size of the charging hose fitting (1/2 UNF, 20 threads).
- The packing must also be made of an HFC-resistant material.

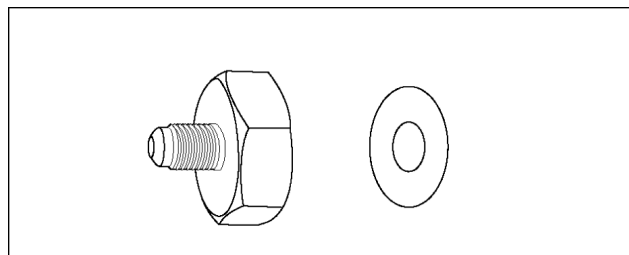

Fig. 9 Charging orifice and packing

10.2.3. R410A Tools Which Are Usable for R22 Models

Table 9 R410A tools which are usable for R22 models

	R410A tools	Usable for R22 models
(1)	Copper tube gauge for clearance adjustment	OK
(2)	Flaring tool (clutch type)	OK
(3)	Manifold gauge	NG
(4)	Charging hose	NG
(5)	Vacuum pump adaptor	OK
(6)	Electric gas leak detector for HFC refrigerant	NG
(7)	Electronic scale for refrigerant charging	OK
(8)	Refrigerant cylinder	NG
(9)	Charging orifice and packing for refrigerant cylinder	NG

10.3. Refrigerant Piping Work

10.3.1. Piping Materials

It is recommended that you use copper and copper alloy jointless pipes with a maximum oil adherence of 40 mg/10m. Do not use pipes that are crushed, deformed, or discolored (especially the inside surface). If these inferior pipes are used, impurities may clog the expansion valves or capillaries.

Because the pressure of ACs using R410A is higher than those using R22, it is essential that you select materials that are appropriate for these standards.

The thickness of the copper tubing used for R410A is shown in Table 10. Please be aware that tubing with a thickness of only 0.7 mm is also available on the market, but this should never be used.

Table 10 Copper tube thickness (mm)

Soft pipe		Thickness (mm)	
Nominal diameter	Outside diameter (mm)	R410A	(Reference) R22
1/4	6.35	0.80	0.80
3/8	9.52	0.80	0.80
1/2	12.7	0.80	0.80

10.3.2. Processing and Connecting Piping Materials

When working with refrigerant piping, the following points must be carefully observed: no moisture or dust must be allowed to enter the piping, and there must be no refrigerant leaks.

1. Procedure and precautions for flaring work

a. Cut the pipe

Use a pipe cutter, and cut slowly so the pipe will not be deformed.

b. Remove burrs and clean shavings from the cut surface

If the shape of the pipe end is poor after removing burrs, or if shavings adhere to the flared area, it may lead to refrigerant leaks.

To prevent this, turn the cut surface downward and remove burrs, then clean the surface, carefully.

c. Insert the flare nut (be sure to use the same nut that is used on the AC unit)

d. Flaring

Check the clamp bar and the cleanliness of the copper pipe.

Be sure to use the clamp bar to do the flaring with accuracy. Use either an R410A flaring tool, or a conventional flaring tool. Flaring tools come in different sizes, so be sure to check the size before using. When using a conventional flaring tool, use the copper pipe gauge for clearance adjustment, etc., to ensure the correct A dimension (see Fig. 10)

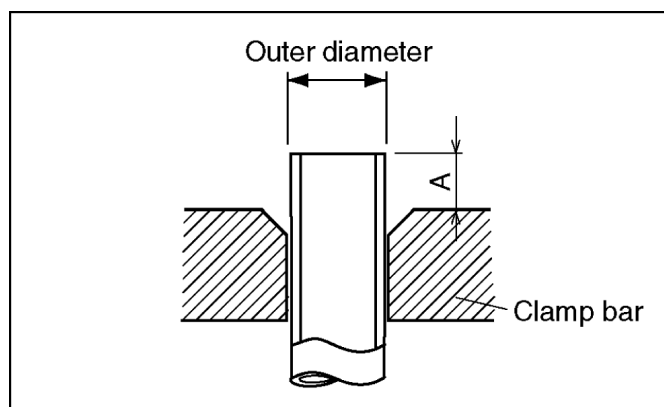

Fig. 10 Flaring dimensions

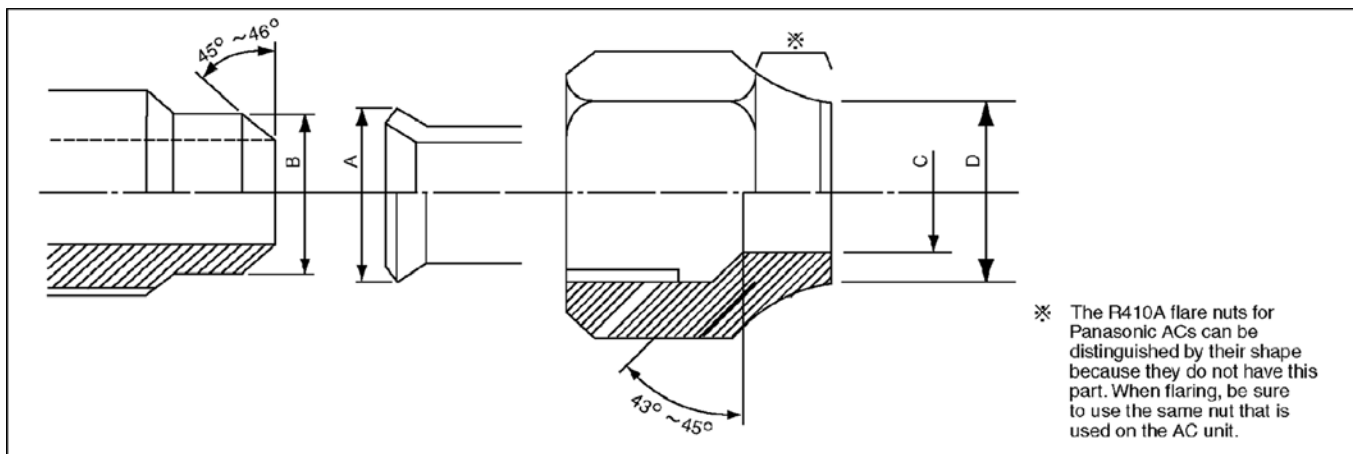

Fig. 11 Relation between the flare nut structure and flaring tool end

Table 11 R410A flaring dimensions

Nominal diameter	Outside diameter (mm)	Wall thickness (mm)	A (mm)		
			R410A flaring tool, clutch type	Conventional flaring tool	
				Clutch type	Wing-nut type
1/4	6.35	0.8	0 - 0.5	1.0 - 1.5	1.5 - 2.0
3/8	9.52	0.8	0 - 0.5	1.0 - 1.5	1.5 - 2.0
1/2	12.70	0.8	0 - 0.5	1.0 - 1.5	2.0 - 2.5

Table 12 R22 flaring dimensions

Nominal diameter	Outside diameter (mm)	Wall thickness (mm)	A (mm)		
			R410A flaring tool, clutch type	Conventional flaring tool	
				Clutch type	Wing-nut type
1/4	6.35	0.8	0 - 0.5	0.5 - 1.0	1.0 - 1.5
3/8	9.52	0.8	0 - 0.5	0.5 - 1.0	1.0 - 1.5
1/2	12.70	0.8	0 - 0.5	0.5 - 1.0	1.5 - 2.0

Table 13 R410A flare and flare nut dimensions Unit: mm

Nominal diameter	Outside diameter (mm)	Wall thickness (mm)	A +0, -0.4	B dimension	C dimension	D dimension	Flare nut width
1/4	6.35	0.8	9.1	9.2	6.5	13	17
3/8	9.52	0.8	13.2	13.5	9.7	20	22
1/2	12.70	0.8	16.6	16.0	12.9	23	26

Table 14 R22 flare and flare nut dimensions Unit: mm

Nominal diameter	Outside diameter (mm)	Wall thickness (mm)	A +0, -0.4	B dimension	C dimension	D dimension	Flare nut width
1/4	6.35	0.8	9.0	9.2	6.5	13	17
3/8	9.52	0.8	13.0	13.5	9.7	20	22
1/2	12.70	0.8	16.2	16.0	12.9	20	24

2. Procedure and precautions for flare connection

- a. Check to make sure there is no scratches, dust, etc., on the flare and union.
- b. Align the flared surface with the axial center of the union.
- c. Use a torque wrench, and tighten to the specified torque. The tightening torque for R410A is the same as the conventional torque value for R22. Be careful, because if the torque is too weak, it may lead to a gas leak. If it is too strong, it may split the flare nut or make it impossible to remove the flare nut.

Table 15 R410A tightening torque

Nominal diameter	Outside diameter (mm)	Tightening torque N.m (kgf.cm)	Torque wrench tightening torque N.m (kgf.cm)
1/4	6.35	14 - 18 (140 - 180)	18 (180)
3/8	9.52	33 - 42 (330 - 420)	42 (420)
1/2	12.70	55 (550)	55 (550)

10.3.3. Storing and Managing Piping Materials

1. Types of piping and their storage

The following is a general classification of the refrigerant pipe materials used for ACs.

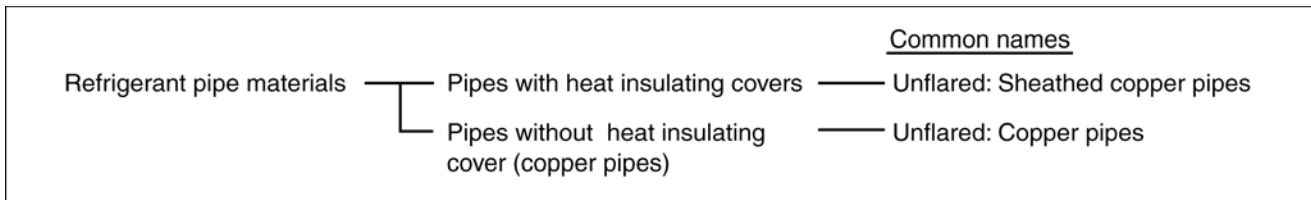

Because the gas pressure of R410A is approximately 1.6 times as high as that of R22, copper pipes with the thickness shown in Table 10, and with minimal impurities must be used. Care must also be taken during storage to ensure that pipes are not crushed, deformed, or scratched, and that no dust, moisture or other substance enters the pipe interior. When storing sheathed copper pipes or plain copper pipes, seal the openings by pinching or taping them securely.

2. Makings and management

- a. Sheathed copper pipes and copper-element pipes
When using these pipes, check to make sure that they are the stipulated thickness. For flare nuts, be sure to use the same nut that is used on the AC unit.

b. Copper pipes

Use only copper pipes with the thickness given in table 10, and with minimal impurities. Because the surface of the pipe is exposed, you should take special care, and also take measures such as marking the pipes to make sure they are easily distinguished from other piping materials, to prevent mistaken use.

3. Precautions during refrigerant piping work

Take the following precautions on-site when connecting pipes. (Keep in mind that the need to control the entry of moisture and dust is even more important than in conventional piping).

- a. Keep the open ends of all pipes sealed until connection with AC equipment is complete.
- b. Take special care when doing piping work on rainy days. The entering of moisture will degrade the refrigerating machine oil, and lead to malfunctions in the equipment.
- c. Complete all pipe connections in as short a time as possible. If the pipe must be left standing for a long time after removing the seal, it must be thoroughly purged with nitrogen, or dried with a vacuum pump.

10.4. Installation, Transferring, Servicing

10.4.1. Inspecting Gas Leaks with a Vacuum Pump for New Installations (Using New Refrigerant Piping)

1. From the viewpoint of protecting the global environment, please do not release refrigerant into the atmosphere.
 - a. Connect the projecting side (pin-pushing side) of the charging hose for the manifold gauge to the service port of the 3-way valve. (1)
 - b. Fully open the handle Lo of the manifold gauge and run the vacuum pump. (2) (If the needle of the low-pressure gauge instantly reaches vacuum, re-check step a.)
 - c. Continue the vacuum process for at least 15 minutes, then check to make sure the low-pressure gauge has reached -0.1 MPa (-76 cmHg). Once the vacuum process has finished, fully close the handle Lo of the manifold gauge and stop the vacuum pump operation, then remove the charging hose that is connected to the vacuum pump adaptor. (Leave the unit in that condition for 1-2 minutes, and make sure that the needle of the manifold gauge does not return.) (2) and (3)
 - d. Turn the valve stem of the 2-way valve 90° counter-clockwise to open it, then, after 10 seconds, close it and inspect for a gas leak (4)
 - e. Remove the charging hose from the 3-way valve service port, then open both the 2-way valve and 3-way valve. (1) (4) (Turn the valve stem in the counter-clockwise direction until it gently makes contact. Do not turn it forcefully).
 - f. Tighten the service port cap with a torque wrench (18 N.m (1.8 kgf.m)). (5) Then tighten the 2-way valve and 3-way valve caps with a torque wrench (42 N.m (4.2 kgf.m)) or (55 N.m (5.5 kgf.m)). (6)
 - g. After attaching each of the caps, inspect for a gas leak around the cap area. (5) (6)

Precautions

- Be sure to read the instructions for the vacuum pump, vacuum pump adaptor and manifold gauge prior to use, and follow the instructions carefully.
- Make sure that the vacuum pump is filled with oil up to the designated line on the oil gauge.
- The gas pressure back flow prevention valve on the charging hose is generally open during use. When you are removing the charging hose from the service port, it will come off more easily if you close this valve.

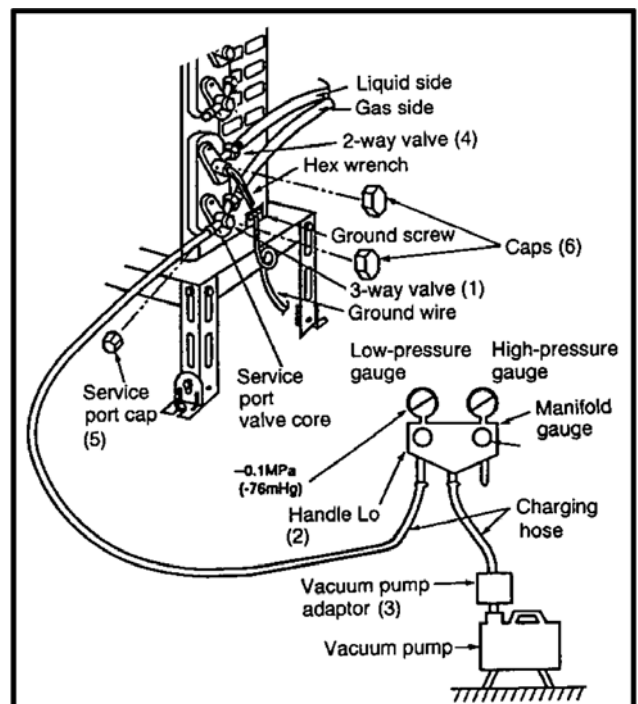

Fig. 12 Vacuum pump air purging configuration

10.4.2. Transferring (Using New Refrigerant Piping)

1. Removing the unit

a. Collecting the refrigerant into the outdoor unit by pumping down

The refrigerant can be collected into the outdoor unit (pumping down) by pressing the TEST RUN button, even when the temperature of the room is low.

- Check to make sure that the valve stems of the 2-way valve and 3-way valve have been opened by turning them counter-clockwise. (Remove the valve stem caps and check to see that the valve stems are fully opened position. Always use a hex wrench (with 4-mm opposing sides) to operate the valve stems.)
- Press the TEST RUN button on the indoor unit, and allow preliminary operation for 5-6 minutes. (TEST RUN mode)
- After stopping the operation, let the unit sit for about 3 minutes, then close the 2-way valve by turning the valve stem in the clockwise direction.
- Press the TEST RUN button on the indoor unit again, and after 2-3 minutes of operation, turn the valve stem of the 3-way valve quickly in the clockwise direction to close it, then stop the operation.
- Tighten the caps of the 2-way valve and 3-way valve to the stipulated torque.
- Remove the connection pipes (liquid side and gas side).

b. Removing the indoor and outdoor units.

- Disconnect the pipes and connecting electric cables from between the indoor and outdoor units.
- Put capped flare nuts onto all of the pipe connections of the indoor and outdoor units, to make sure no dust or other foreign matter enters.
- Remove the indoor and outdoor units.

2. Installing the unit

Install the unit using new refrigerant piping. Follow the instructions in section 4.1 to evacuate the pipes connecting the indoor and outdoor units, and the pipes of the indoor unit, and check for gas leaks.

10.4.3. AC Units Replacement (Using Existing Refrigerant Piping)

When replacing an R410A AC unit with another R410A AC unit, you should re-flare the refrigerant piping. Even though the replacement AC unit uses the R410A, problems occur when, for example, either the AC unit maker or the refrigerating machine oil is different.

When replacing an R22 AC unit with an R410A AC unit, the following checks and cleaning procedures are necessary but are difficult to do because of the chemical characteristics of the refrigerating machine oil (as described in items c) and d) of section **About R410A Refrigerant**). In this case, you should use new refrigerant piping rather than the existing piping.

1. Piping check

Because of the different pressure characteristics of R22 and R410A, the design pressure for the equipment is 1.6 times different. the wall thickness of the piping must comply with that shown in Table 10, but this is not easy to check. Also, even if the thickness is correct, there may be flattened or bent portions midway through the piping due to sharp curves. Buried sections of the piping also cannot be checked.

2. Pipe cleaning

A large quantity of refrigerating machine oil (mineral oil) adheres to existing pipes due to the refrigeration cycle circulation. If the pipes are used just as they are for the R410A cycle, the capacity will be lowered due to the incompatibility of this oil with the R410A, or irregularities may occur in the refrigeration cycle. For this reason, the piping must be thoroughly cleaned, but this is difficult with the present technology.

10.4.4. Refrigerant Compatibility (Using R410A Refrigerant in R22 ACs and Vice Versa)

Do not operate an existing R22 AC with the new R410A refrigerant. Doing so would result in improper functioning of the equipment or malfunction, and might lead to a major accident such as an explosion in the refrigeration cycle. Similarly, do not operate an R410A AC with R22 refrigerant. The chemical reaction between the refrigerating machine oil used in R410A ACs and the chlorine that is contained in R22 would cause the refrigerating machine oil to degrade and lead to malfunction.

10.4.5. Recharging Refrigerant During Servicing

When recharging is necessary, insert the specified amount of new refrigerant in accordance with the following procedure.

1. Connect the charging hose to the service port of the outdoor unit.
2. Connect the charging hose to the vacuum pump adaptor. At this time, fully open the 2-way valve and 3-way valve.
3. Fully open the handle Lo of the manifold gauge, turn on the power of the vacuum pump and continue the vacuum process for at least one hour.
4. Confirm that the low pressure gauge shows a reading of -0.1 Mpa (-76 cmHg), then fully close the handle Lo, and turn off the vacuum pump. Wait for 1-2 minutes, then check to make sure that the needle of the Low pressure gauge has not returned. See Fig. 13 for the remaining steps of this procedure.
5. Set the refrigerant cylinder onto the electronic scale, then connect the hose the cylinder and to the connection port for the electronic scale. (1)(2)

Precaution:

Be sure to set up the cylinder for liquid charging. If you use a cylinder equipped with a siphon tube, you can charge the liquid without having to turn the cylinder around

6. Remove the charging hose of the manifold gauge from the vacuum pump adaptor, and connect it to the connection port of the electronic scale. (2)(3)
7. Open the valve of the refrigerant cylinder, then open the charging valve slightly and close it. Next, press the check valve of the manifold gauge and purge the air. (2)(4) (Watch the liquid refrigerant closely at this point.)
8. After adjusting the electronic scale to zero, open the charging valve, then open the valve Lo of the manifold gauge and charge with the liquid refrigerant. (2)(5) (Be sure to read the operating instructions for the electronic scale.)
9. If you cannot charge the stipulated amount, operate the unit in the cooling mode while charging a little of the liquid at a time (about 150 g/time as a guideline). If the charging amount is insufficient from one operation, wait about one minute, then use the same procedure to do the liquid charging again.

Precaution:

Never use the gas side to allow a larger amount of liquid refrigerant to be charged while operating the unit.

10. Close the charging valve, and after charging the liquid refrigerant inside the charging hose, fully close the valve Lo of the manifold gauge, and stop the operation of the unit. (2)(5)
11. Quickly remove the charging hose from the service port. (6) If you stop midway through, the refrigerant that is in the cycle will be discharged.
12. After putting on the caps for the service port and operating valve, inspect around the caps for a gas leak. (6)(7)

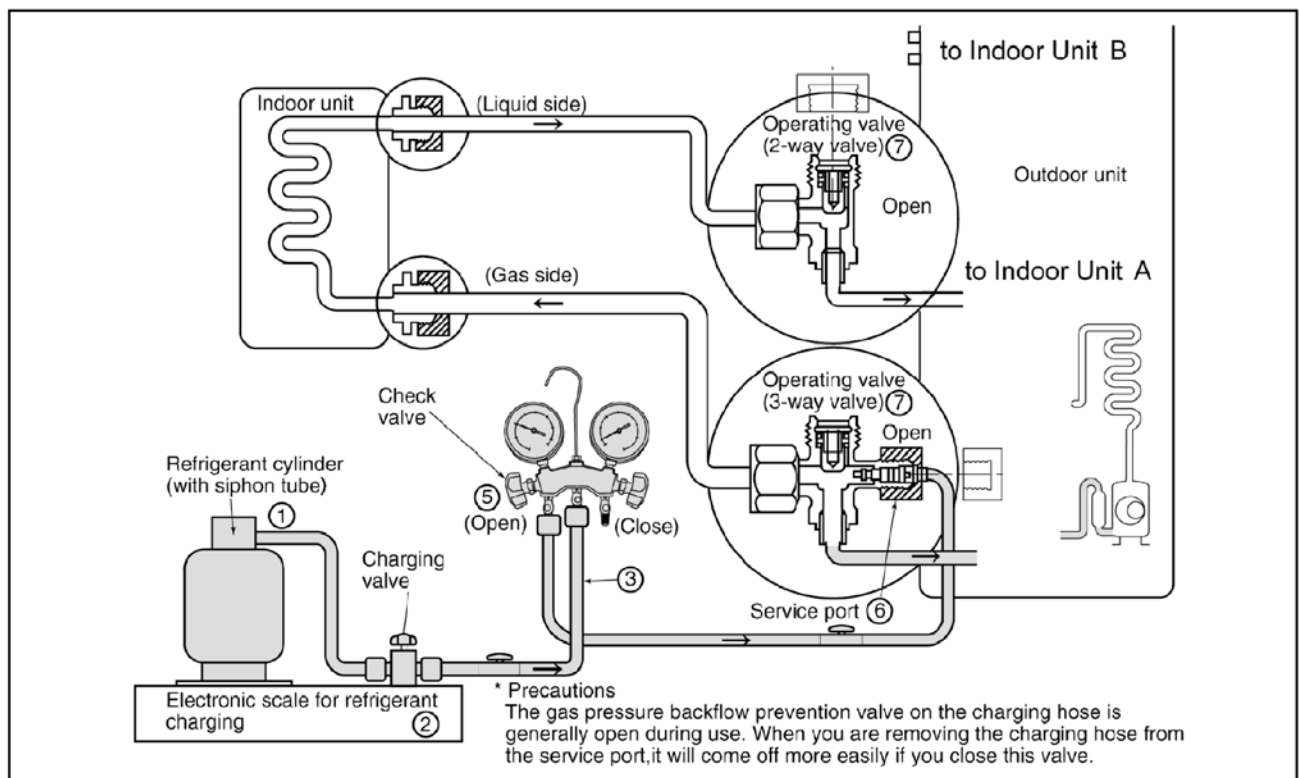

Fig. 13 Re-charging refrigerant

10.4.6. Brazing

As brazing requires sophisticated techniques and experiences, it must be performed by a qualified person.

In order to prevent the oxide film from occurring in the pipe interior during brazing, it is effective to proceed with brazing while letting dry nitrogen gas (N₂) flow.

<Brazing Method for Preventing Oxidation>

1. Attach a reducing valve to the nitrogen gas cylinder.
2. Apply a seal onto the clearance between the piping and inserted pipe for the nitrogen gas in order to prevent the nitrogen gas from flowing backward.
3. When the nitrogen gas is flowing, be sure to keep the piping end open.
4. Adjust the flow rate of nitrogen gas so that it is lower than 0.05 m³/h, or 0.02 MPa (0.2 kgf/cm²) by means of the reducing valve.
5. After taking the steps above, keep the nitrogen gas flowing until the piping cools down to a certain extent (i.e. temperature at which pipes are touchable with finger).
6. Completely remove the flux after brazing.

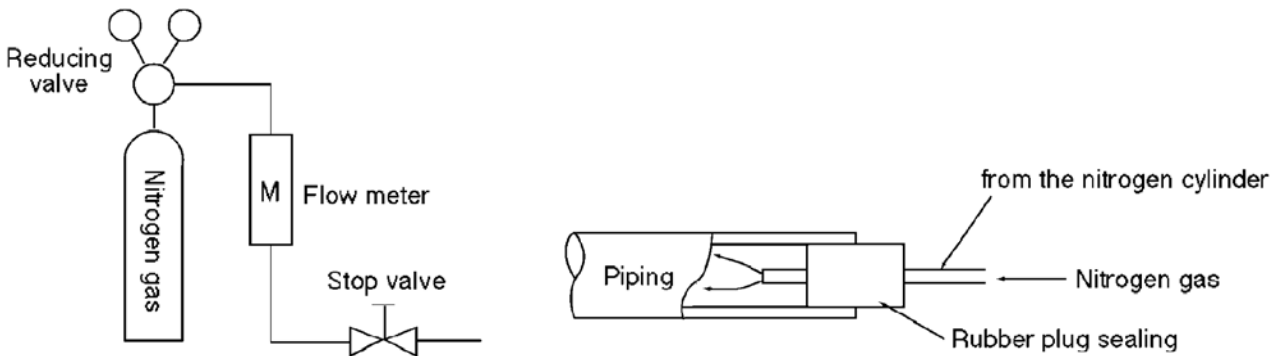

Fig. 14 Prevention of Oxidation during Brazing

Cautions during brazing

1. General Cautions

- a. The brazing strength should be high as required.
- b. After operation, airtightness should be kept under pressurized condition.
- c. During brazing do not allow component materials to become damaged due to overheating.
- d. The refrigerant pipe work should not become blocked with scale or flux.
- e. The brazed part should not restrict the flow in the refrigerant circuit.
- f. No corrosion should occur from the brazed part.

2. Prevention of Overheating

Due to heating, the interior and exterior surfaces of treated metal may oxidize. Especially, when the interior of the refrigerant circuit oxidizes due to overheating, scale occurs and stays in the circuit as dust, thus exerting a fatally adverse effect. So, make brazing at adequate brazing temperature and with minimum of heating area.

3. Overheating Protection

In order to prevent components near the brazed part from overheating damage or quality deterioration due to flame or heat, take adequate steps for protection such as (1) by shielding with a metal plate, (2) by using a wet cloth, and (3) by means of heat absorbent.

4. Movement during Brazing

Eliminate all vibration during brazing to protect brazed joints from cracking and breakage.

5. Oxidation Preventative

In order to improve the brazing efficiency, various types of antioxidant are available on the market. However, the constituents of these are widely varied, and some are anticipated to corrode the piping materials, or adversely affect HFC refrigerant, lubricating oil, etc. Exercise care when using an oxidation preventative.

10.4.7. Servicing Tips



The drier must also be replaced whenever replacing the refrigerant cycle parts. Replacing the refrigerant cycle parts first before replacing the drier. The drier is supplied in a vacuum pack. Perform brazing immediately after opening the vacuum pack, and then start the vacuum within two hours. In addition, the drier also needs to be replaced when the refrigerant has leaked completely. (Applicable for drier models only)

11 Installation Instructions

11.1. Safety Precautions

- Read the following "SAFETY PRECAUTIONS" carefully before installation.
- Electrical work must be installed by a licensed electrician. Be sure to use the correct rating of the power plug and main circuit for the model to be installed.
- The caution items stated here must be followed because these important contents are related to safety. The meaning of each indication used is as below.





Incorrect installation due to ignoring of the instruction will cause harm or damage, and the seriousness is classified by the following indications.

 WARNING	This indication shows the possibility of causing death or serious injury.
 CAUTION	This indication shows the possibility of causing injury or damage to properties only.

The items to be followed are classified by the symbols:

	Symbol with background white denotes item that is PROHIBITED from doing.
-----------------------------------------------------------------------------------	--------------------------------------------------------------------------

- Carry out test running to confirm that no abnormality occurs after the installation. Then, explain to user the operation, care and maintenance as stated in instructions. Please remind the customer to keep the operating instructions for future reference.

 WARNING	
1. Engage dealer or specialist for installation. If installation done by the user is defective, it will cause water leakage, electrical shock or fire.	
2. Install according to this installation instructions strictly. If installation is defective, it will cause water leakage, electrical shock or fire.	
3. Use the attached accessories parts and specified parts for installation. Otherwise, it will cause the set to fall, water leakage, fire or electrical shock.	
4. Install at a strong and firm location which is able to withstand the set's weight. If the strength is not enough or installation is not properly done, unit will drop and cause injury.	
5. For electrical work, please follow the local national wiring standard & regulation and this installation instructions. An independent circuit and single outlet must be used. If electrical circuit capacity is not enough or defect found in electrical work, it will cause electrical shock or fire.	
6. Use the specified cable and connect tightly for indoor/outdoor connection. Please clamp the cable firmly so that no external force will be acted on the terminal. If connection or fixing is not perfect, it will cause heat-up or fire at the connection.	
7. Wire routing must be properly arranged so that control board cover is fixed properly. If control board cover is not fixed perfectly, it will cause heat-up at connection point of terminal, fire or electrical shock.	
8. When carrying out piping connection, please take care not to let air or other substances other than the specified refrigerant go into refrigeration cycle. Otherwise, it will cause lower capacity, abnormal high pressure in the refrigeration cycle, explosion and injury.	
9. When connecting the piping, do not allow air or any substances other than the specified refrigerant (R410A) to enter the refrigeration cycle. Otherwise, this may lower the capacity, cause abnormally high pressure in the refrigeration cycle, and possibly result in explosion and injury.	
10. <ul style="list-style-type: none"> • When connecting the piping, do not use any existing (R22) pipes and flare nuts. Using such same may cause abnormally high pressure in the refrigeration cycle (piping), and possibly result in explosion and injury. Use only R410A materials. • Thickness of copper pipes used with R410A must be more than 0.8 mm. Never use copper pipes thinner than 0.8 mm. • It is desirable that the amount of residual oil is less than 40 mg/10 m. 	
11. Do not modify the length of the power supply cord or use of the extension cord, and do not share the single outlet with other electrical appliances. Otherwise, it will cause fire or electrical shock.	

⚠ CAUTION

1. This equipment must be earthed. It may cause electrical shock if grounding is not perfect.
2. Do not install the unit at place where leakage of flammable gas may occur. In case gas leaks and accumulates at surrounding of the unit, it may cause fire. 
3. Carry out drainage piping as mentioned in installation instructions. If drainage is not perfect, water may enter the room and damage the furniture.

ATTENTION

1. Selection of the installation location and installation.
Select an installation location which is rigid and strong enough to support or hold the unit, and select a location for easy maintenance.
2. Power supply connection to the room air conditioner.
Connect the power supply cord of the room air conditioner to the mains using one of the following method.
Power supply point shall be the place where there is ease for access for the power disconnection in case of emergency.
In some countries, permanent connection of this room air conditioner to the power supply is prohibited.
 1. Power supply connection to the socket using a power plug.
Use an approved 15A power plug with earth pin for the connection to the socket.
 2. Power supply connection to a circuit breaker for the permanent connection. Use an approved 16A circuit breaker for the permanent connection. It must be a double pole switch with a minimum 3.5 mm contact gap.
3. Do not release refrigerant.
Do not release refrigerant during piping work for installation, re-installation and during repairing a refrigeration parts. Take care of the liquid refrigerant, it may cause frostbite.
4. Installation work.
It may need two people to carry out the installation work.
5. Do not install this appliance in a laundry room or other location where water may drip from the ceiling, etc.

Attached accessories

Name		Qty.
Drain hose with a clip		1
Heat Insulator		2
Band		4
Flat washer for M10		8
Screw M5		4
Remote Control		1
Remote control holder		1
Remote control holder fixing screw		2
Battery		2
Drain elbow		1

Applicable piping kit
CZ-4F5, 7, 10BP

Select the best location

OUTDOOR UNIT

- If an awning is built over the unit to prevent direct sunlight or rain, be careful that heat radiation from the condenser is not obstructed.
- There should not be any animal or plant which could be affected by hot air discharged.
- Keep the spaces indicated by arrows from wall, ceiling, fence or other obstacles.
- Do not place any obstacles which may cause a short circuit of the discharged air.
- If piping length is over 10m, additional refrigerant should be added as shown in the table.

Model	Piping size		Max. Piping Length (m)	Max. Elevation (m)	Rated Length (m)	Additional Refrigerant (g/m)
	Gas	Liquid				
E18/21D	1/2"	1/4"	20	15	5	20
E15D	1/2"	1/4"	20	15	7.5	20

Example:
Of the unit is installed at a 12m distance, the quantity of additional refrigerant should be 40g.....(12-10)m x 20g/m = 40g

11.2. Indoor Unit

11.2.1. SELECTING THE LOCATION FOR THE INDOOR UNIT

Provide a check port on the piping side ceiling for repair and maintenance.

- Install the indoor unit once the following conditions are satisfied and after receiving the customer approval.
 1. The indoor unit must be within a maintenance space.
 2. The indoor unit must be free from any obstacles in path of the air inlet and outlet, and must allow spreading of air throughout the room.
 3. Recommended installation height for indoor unit shall be at least 2.5 m.

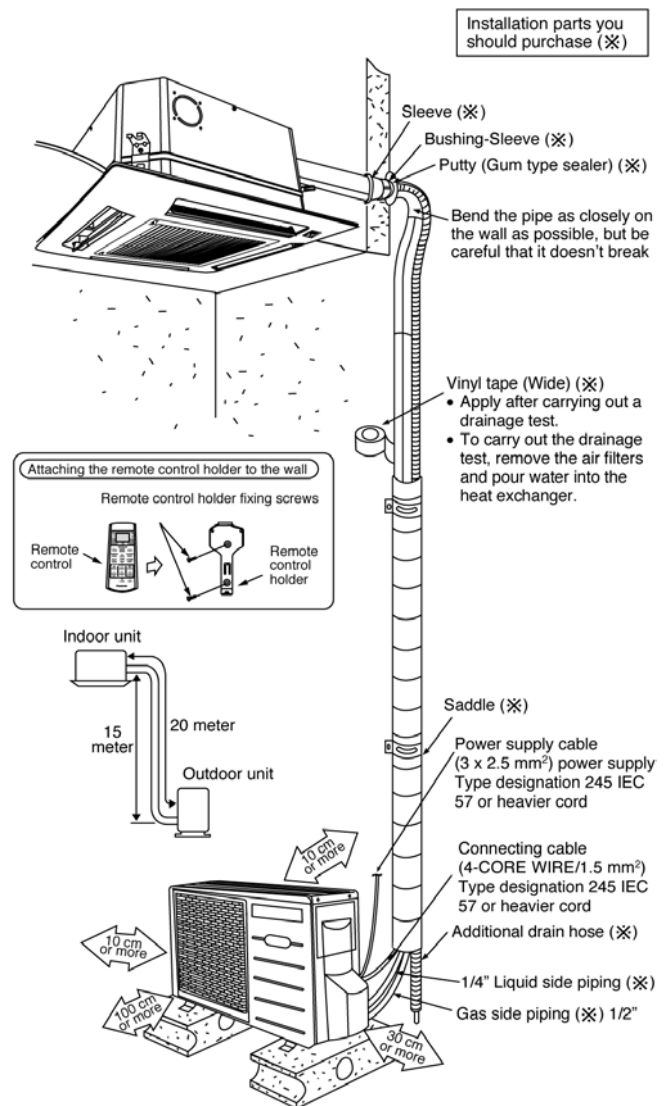

- This illustration is for explanation purposes only. The indoor unit will actually face a different way.

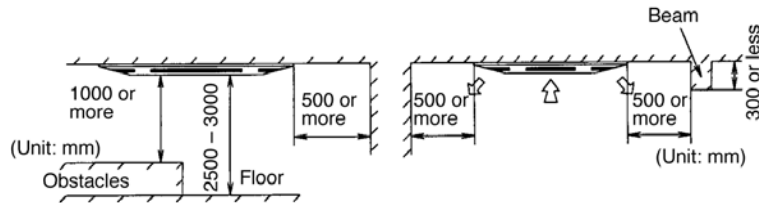

* If the height from the floor to ceiling exceeds three meters, air flow distribution deteriorates and the effect is decreased.

⚠ WARNING

4. The installation position must be able to support a load four times the indoor unit weight.
5. The indoor unit must be away from heat and steam sources, but avoid installing it near an entrance.
6. The indoor unit must allow easy draining.
7. The indoor unit must allow easy connection to the outdoor unit.
8. Place the indoor unit according to the height from the ceiling shown in the illustration below.
9. The indoor unit must be from at least 3m away from any noise-generating equipment. The electrical wiring must be shielded with a steel conduit.
10. If the power supply is subject to noise generation, add a suppressor.
11. Do not install the indoor unit in a laundry. Electric shocks may result.

NOTE

– Thoroughly study the following installation locations

1. In such places as restaurants and kitchens, considerable amount of oil steam and flour adhere to the turbo fan, the fin of the heat exchanger and the drain pump, resulting in heat exchange reduction, spraying, dispersing of water drops, drain pump malfunction, etc.

In these cases, take the following actions:

- Make sure that the ventilation fan for smoke-collecting hood on a cooking table has sufficient capacity so that it draws oily steam which should not flow into the suction of the air conditioner.
- Make enough distance from the cooking room to install the air conditioner in such place where it may not suck in oily steam.

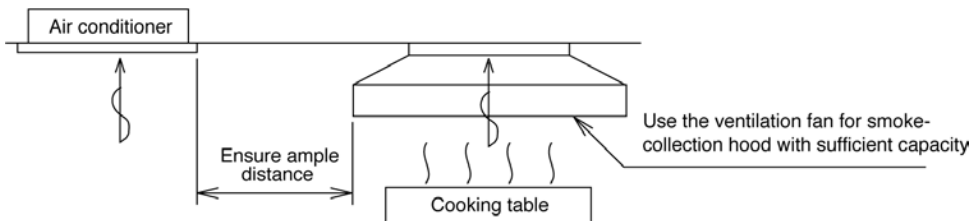

2. Avoid installing the air conditioner in such circumstances where cutting oil mist or iron powder exist especially in factories, etc.
3. Avoid places where inflammable gas is generated, flows-in, contaminated, or leaked.
4. Avoid places where sulphurous acid gas or corrosive gas can be generated.
5. Avoid places near high frequency generators.

Model Name	Height in the ceiling
CS-E15DB4**	280 mm or more
CS-E21DB4**	
CS-E18DB4**	

11.2.2. INSTALLATION OF INDOOR UNIT

This air conditioner uses a drain up motor. Horizontally install the unit using a level gauge.

CEILING OPENING DIMENSIONS AND HANGING BOLT LOCATION

The paper model for installation expand or shrink according to temperature and humidity.

Check on dimensions before using it.

CAUTION	During the installation, care must be taken not to damage electric wires.
---------	---------------------------------------------------------------------------

- The dimensions of the paper model for installations the same as those of the ceiling opening dimensions.
- Be sure to discuss the ceiling drilling work with the workers concerned.

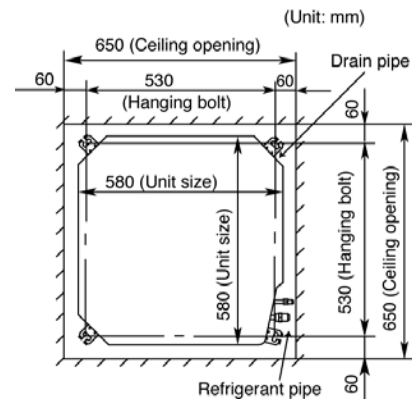

POSITIONS OF AIR CONDITIONER BODY AND CEILING SURFACE

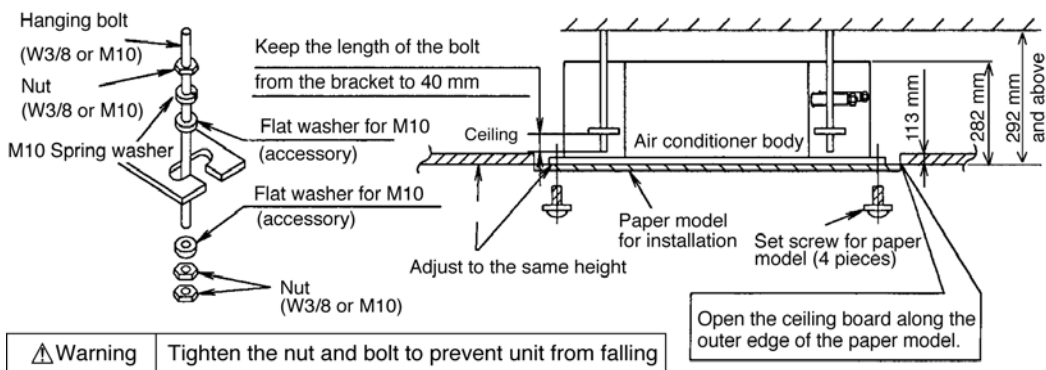

11.2.3. REFRIGERANT PIPING

Refrigerant is charged to the outdoor unit. For details, see the manual for installation work of outdoor unit. (Additional charging, etc.)

1. Brazing for piping.
 - a. Execute brazing before tightening the flare nut.
 - b. Brazing must be executed while blowing nitrogen gas. (This prevents generation of oxidized scale in copper pipe.)
2. When there is a lot of brazings for long piping, install a strainer midway of the piping. (The strainer is locally supplied.)
3. Use clean copper pipe with inner wall surface free from mist and dust. Blow nitrogen gas or air to blow off dust in the pipe before connection.
4. Form the piping according to its routing. Avoid bending and bending back the same piping point more than three times. (This will result in hardening of the pipe).
5. After deforming the pipe, align centers of the union fitting of the indoor unit and the piping, and tighten them firmly with wrenches.
6. Connect pipe to the service valve or ball valve which is located below the outdoor unit.
7. After completed the piping connection, be sure to check if there is gas leakage in indoor and outdoor connection.

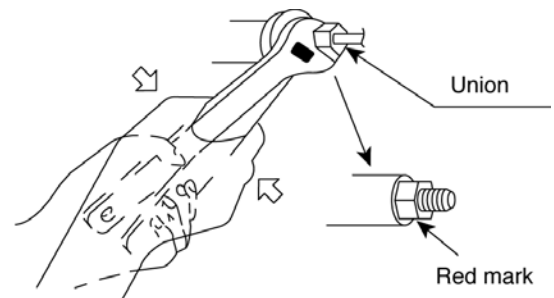

- Confirm the red mark of the union (thin side) is always at lower direction after connecting piping.

Vacuum drying

After completing the piping connection, execute vacuum drying for the connecting piping and the indoor unit. The vacuum drying must be carried out by using the service ports of both the liquid and gas side valves.

CAUTION Use two wrenches and tighten with regular torque

Flare nut fastening torque N-m (kgf-cm)					
ø6.35 mm	18 (180)	ø12.7 mm	55 (560)	ø19.05 mm	100 (1020)
ø9.52 mm	42 (430)	ø15.88 mm	65 (660)		
Liquid size piping			Gas side piping		
ø6.35 mm (1/4")			ø12.7 mm (1/2")		

11.2.4. INDOOR UNIT DRAIN PIPING

- Drain piping must have down-slope (1/50 to 1/100); be sure not to provide up-and-down slope to prevent reversal flow.
- Be sure to check no air trap and to ensure smooth water flow and no abnormal.
- During drain piping connection, be careful not to exert extra force on the drain port at the indoor unit.
- The outside diameter of the drain connection at the indoor unit is 32mm.

Piping material: Polyvinyl chloride pipe VP-25 and pipe fittings.

- Be sure to perform heat insulation on the drain piping.

Heat insulation material: Polyvinylene foam with thickness more than 8 mm (local supply).

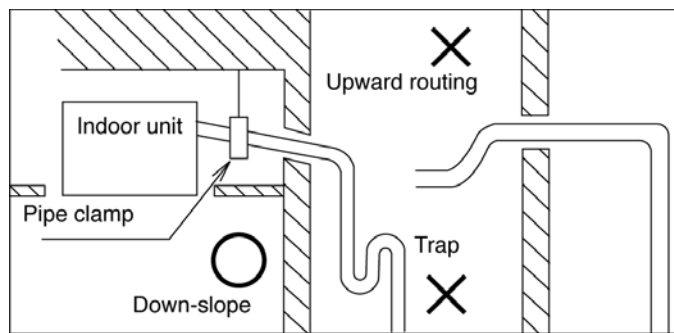

- The height of drain may be possible up to 750 mm.

- When drain set piping, install as shown in the figure below.

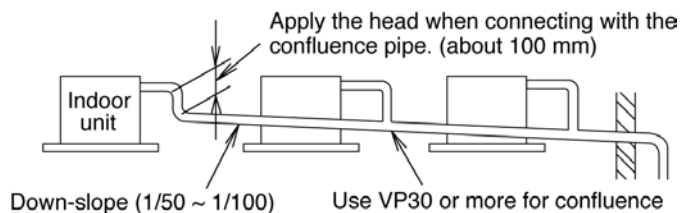
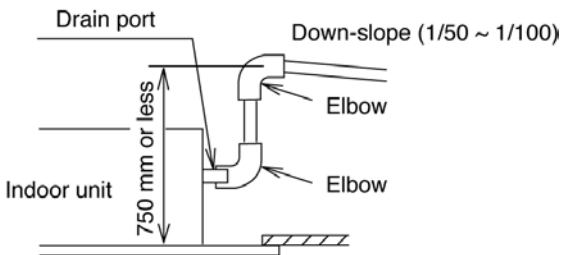

Drain Test

The air conditioner uses a drain up motor to drain water. Use the following procedure to test the drain up motor operation.

- Connect the main drain pipe to exterior and leave it provisionally until the test comes to an end.
- Feed water to the flexible drain hose and check the piping for leakage.
- Be sure to check the drain up motor for normal operating and noise when electric wiring is complete.
- When the test is complete, connect the flexible drain hose to the drain port.
- Pour about 600-700cc of water in the drain pan of the indoor unit. (Pour from the position specified in the drawing by using a water supply bottle or other suitable tool.)
- Press the drain pump test run on pcb to start the drain motor, and verify water drainage. (The drain motor will automatically stop after operating for about five minutes.)

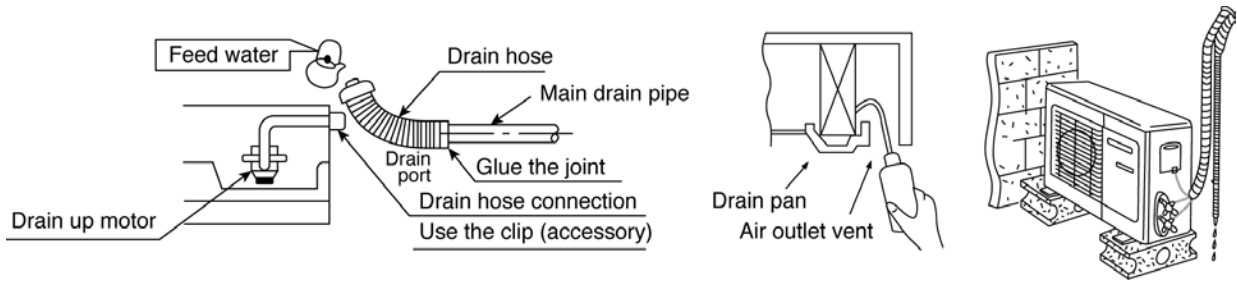

11.2.5. HEAT INSULATION

CAUTION Be sure to perform heat insulation on the drain, liquid and gas piping. Imperfection in heat insulation work leads to water leakage.

1. Use the heat insulation material for the refrigerant piping which has an excellent heat-resistance (over 120°C).

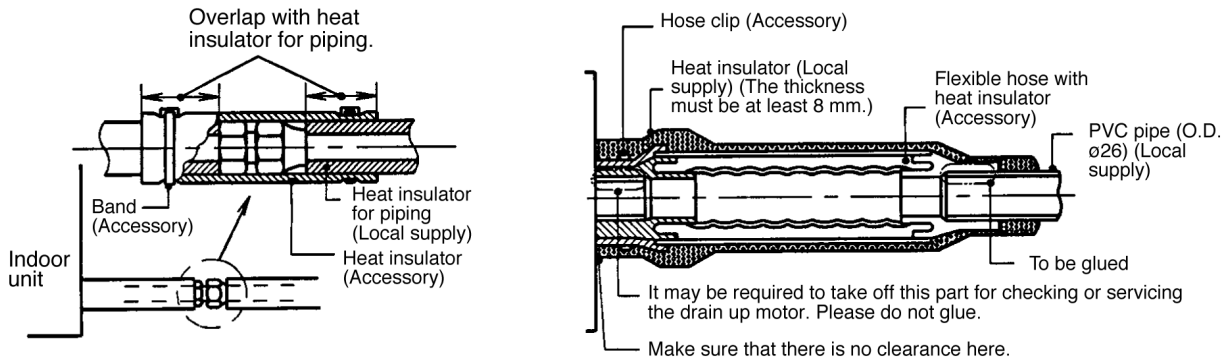

2. Precautions in high humidity circumstance.

This air conditioner has been tested according to the “JIS Standard Conditions with Mist” and have been confirmed that there are no faults. However, if it is operated for a long time in high humid atmosphere (dew point temperature: more than 23°C), water drops are liable to fall. In this case, add heat insulation material according to the following procedure:

- Heat insulation material to be prepared Adiabatic glass wool with thickness 10 to 20 mm.
- Stick glass wool on all air conditioners that are located in ceiling atmosphere.
- In addition to the normal heat insulation (thickness: more than 8 mm) for refrigerant piping (gas piping: thick piping) and drain piping, add a further of 10 mm to 30 mm thickness material.

Wall seal

- When the outdoor unit is installed on a higher position than the indoor unit, install the trap so as not to instill rain water into the wall by transmitting in piping.
- Stuff the space among piping, the electric wire, and- the drain hose with “Putty” and seal the penetration wall hole.

Make sure that rain water do not instill into the wall.

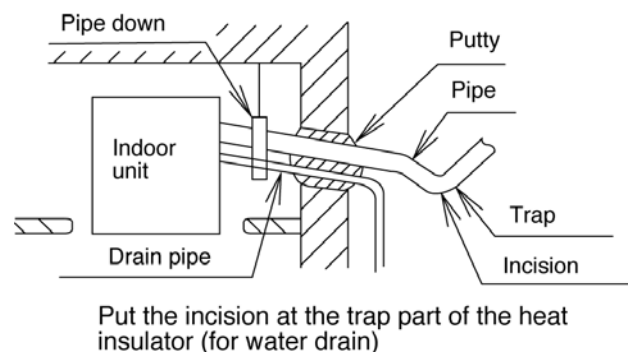

11.2.6. CONNECTING THE CABLE TO THE INDOOR

- Remove the mounting screw, remove the control box cover, and then connect the wires by following the procedure given in the illustration.

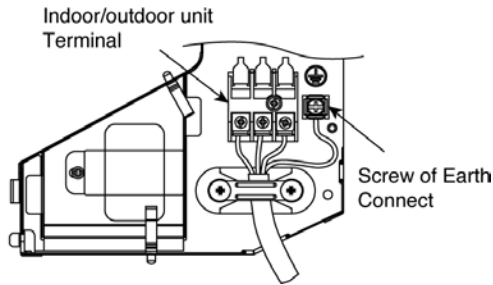
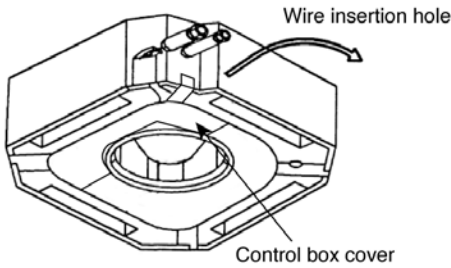

Earth lead wire shall be longer than other wires as shown in the figure for the electrical safety in case of the slipping out of the cord from anchorage.

Terminals on the indoor unit	1	2	3	
Colour of wires				
Terminals on the outdoor unit	1	2	3	

11.2.7. INSTALLATION OF DECORATIVE PANEL

The decorative panel has its installation direction. Confirm the direction by displaying the piping side.

- Remove the air inlet grille by moving the catchers to center.

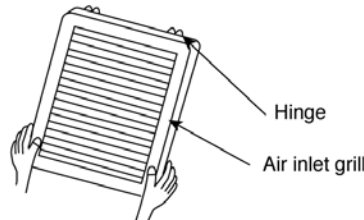
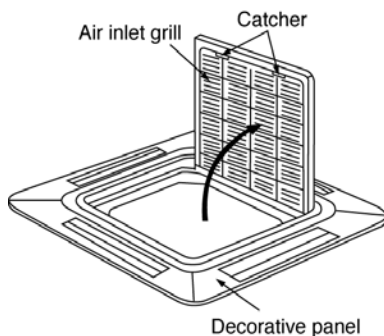

* Hang the hinge on the hole of decorative panel. (The direction of the installation is free.)

- Fitting the decorative panel

- Temporarily secure the fixing screws (3 pcs.) before fitting the decorative panel. (For temporarily securing the front grille.)
- Place decorative panel on the screws (3 pcs.) before fitting, move decorative panel as illustrated and tighten all the screws (4 pcs.).

CAUTION

- Check before hand the height from the ceiling to the unit.
- The front grille fitting direction is determined by the unit direction.
- Only use the screws with the length of 35mm which is provided, to fix the decorative panel.
- Do not use other screw which is longer it may cause damage to the drain-pan and other components.

Tighten until the red marking cannot be seen. Securing the tentative fixing screw. Approx. 20mm

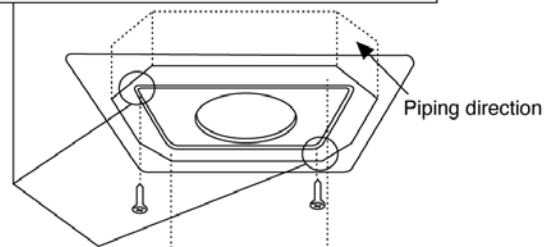

Decorative Panel moving direction

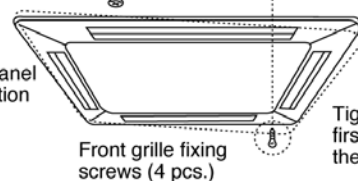

3. Fit the decorative panel and ceiling wall together and confirm no gap in between. Readjust indoor unit height, if there is a gap between ceiling wall and decorative panel.

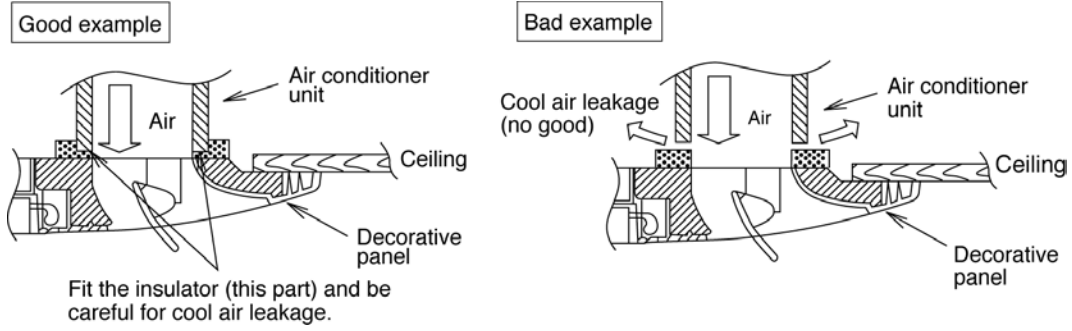

4. Open the indoor control box cover. (2 pcs)
5. Insert firmly the connector of cosmetic louver to indoor pcb CN-STM1, CN-DISP and CN-STM2.
Be caution not to clamp the cord in between control board and control board cover.
6. After complete, install back removed part follow opposite procedure.

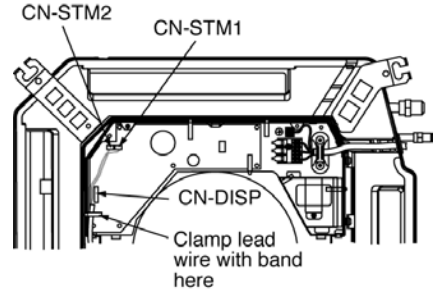

⚠ WARNING Be sure to hook the air inlet grill string, to prevent grill from falling and causing injury from it.

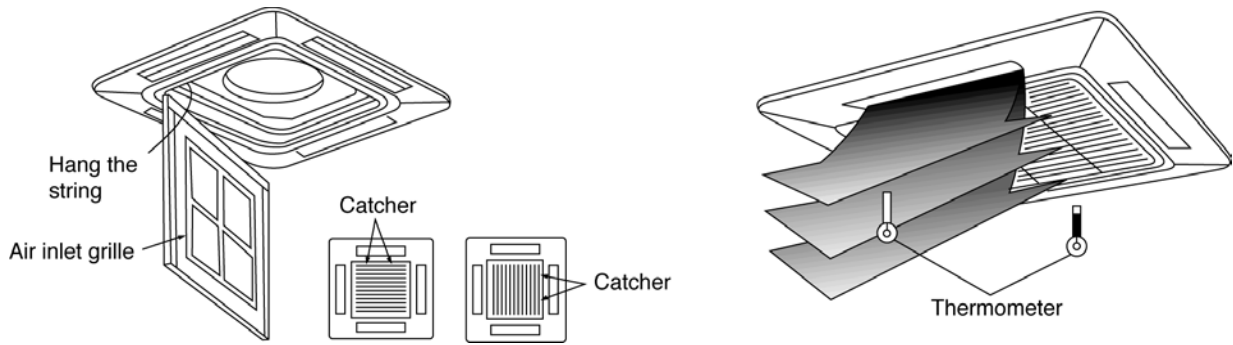

11.3. Outdoor Unit

11.3.1. SELECT THE BEST LOCATION (Refer to “Select the best location” section)

11.3.2. INSTALL THE OUTDOOR UNIT

- After selecting the best location, start installation according to Indoor/Outdoor Unit Installation Diagram.
1. Fix the unit on concrete or rigid frame firmly and horizontally by bolt nut. (ø10 mm).
 2. When installing at roof, please consider strong wind and earthquake. Please fasten the installation stand firmly with bolt or nails.

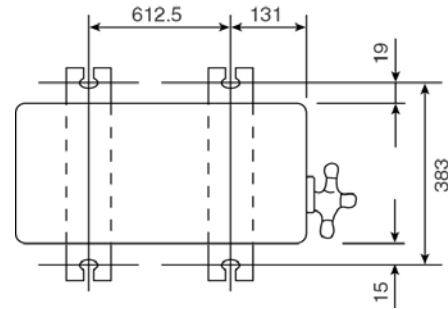

11.3.3. CONNECTING THE PIPING

Connecting The Piping To Indoor Unit

Please make flare after inserting flare nut (locate at joint portion of tube assembly) onto the copper pipe. (In case of using long piping)

Connect the piping

- Align the center of piping and sufficiently tighten the flare nut with fingers.
- Further tighten the flare nut with torque wrench in specified torque as stated in the table.

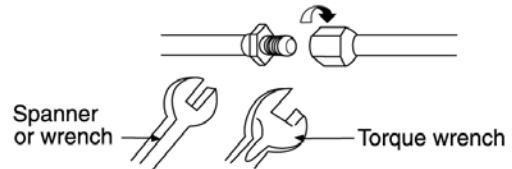

Piping size (Torque)	
Gas	Liquid
1/2" (55 N.m)	1/4" (18 N.m)

Connecting The Piping To Outdoor Unit

Decide piping length and then cut by using pipe cutter. Remove burrs from cut edge. Make flare after inserting the flare nut (located at valve) onto the copper pipe.

Align center of piping to valves and then tighten with torque wrench to the specified torque as stated in the table.

CUTTING AND FLARING THE PIPING

1. Please cut using pipe cutter and then remove the burrs.
2. Remove the burrs by using reamer. If burrs is not removed, gas leakage may be caused.
Turn the piping end down to avoid the metal powder entering the pipe.
3. Please make flare after inserting the flare nut onto the copper pipes.

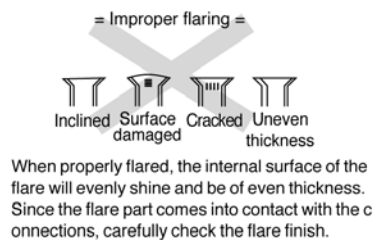
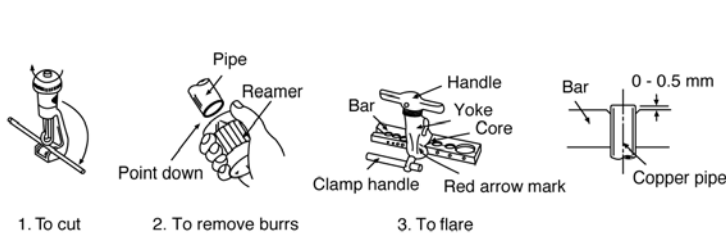

11.3.4. EVACUATION OF THE EQUIPMENT

WHEN INSTALLING AN AIR CONDITIONER, BE SURE TO EVACUATE THE AIR INSIDE THE INDOOR UNIT AND PIPES in the following procedure.

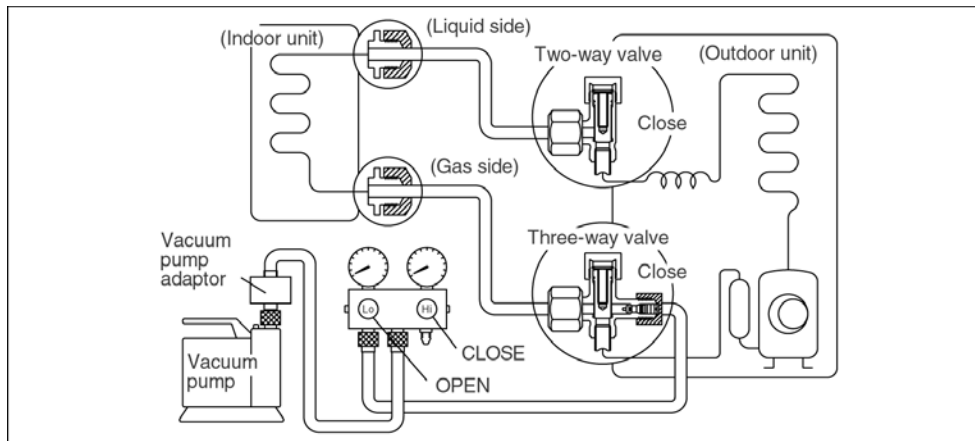

1. Connect a charging hose with a push pin to the Low and High side of a charging set and the service port of the 3-way valve.
 - Be sure to connect the end of the charging hose with the push pin to the service port.
2. Connect the center hose of the charging set to a vacuum pump with check valve, or vacuum pump and vacuum pump adaptor.
3. Turn on the power switch of the vacuum pump and make sure that the needle in the gauge moves from 0 cmHg (0 MPa) to -76 cmHg (-0.1 MPa). Then evacuate the air approximately ten minutes.
4. Close the Low side valve of the charging set and turn off the vacuum pump. Make sure that the needle in the gauge does not move after approximately five minutes.

Note: BE SURE TO FOLLOW THIS PROCEDURE IN ORDER TO AVOID REFRIGERANT GAS LEAKAGE.

5. Disconnect the charging hose from the vacuum pump and from the service port of the 3-way valve.
6. Tighten the service port caps of the 3-way valve at torque of 18 N.m with a torque wrench.
7. Remove the valve caps of both of the 2-way valve and 3-way valve. Position both of the valves to "OPEN" using a hexagonal wrench (4 mm).
8. Mount valve caps onto the 2-way valve and the 3-way valve.
 - Be sure to check for gas leakage.

CAUTION

- If gauge needle does not move from 0 cmHg (0 MPa) to -76 cmHg (-0.1 MPa), in step 3 above take the following measure:
- If the leak stops when the piping connections are tightened further, continue working from step 3.
- If the leak does not stop when the connections are retightened, repair the location of leak.
- Do not release refrigerant during piping work for installation and reinstallation. Take care of the liquid refrigerant, it may cause frostbite.

11.3.5. CONNECT THE CABLE TO THE OUTDOOR UNIT

(FOR DETAIL REFER TO WIRING DIAGRAM AT UNIT)

1. Remove the control board cover from the unit by loosening the screw.
2. Connecting cable between indoor unit and outdoor unit shall be approved polychloroprene sheathed $4 \times 1.5 \text{ mm}^2$ flexible cord, type designation 245 IEC 57 or heavier cord.

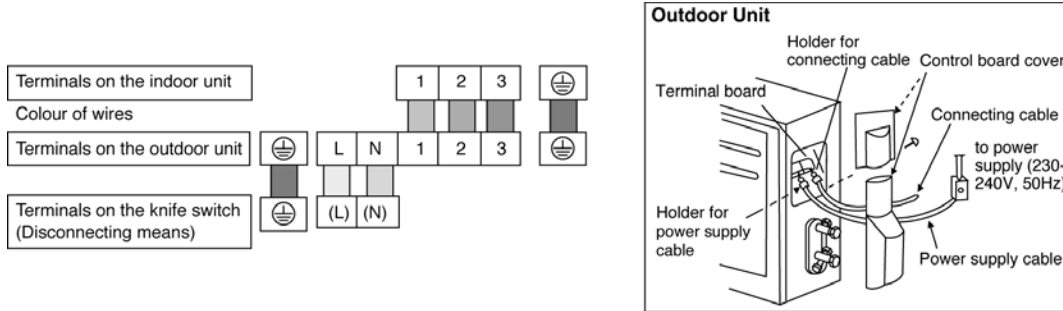

3. Secure the cable onto the control board with the holder (clamer).
4. Cable connection to the power supply through knife switch (Disconnecting means).
 - Connect the approved polychloroprene sheathed power supply cable ($3 \times 2.5 \text{ mm}^2$), type designation 245 IEC 57 or heavier cord to the terminal board, and connect the other end of the cable to knife switch (Disconnecting means).

Note: Knife switch (Disconnecting means) should have minimum 3.5 mm contact gap.

 - Secure the cable onto the control board with the holder (clamer).

11.3.6. PIPE INSULATION

1. Please carry out insulation at pipe connection portion as mentioned in Indoor/Outdoor Unit Installation Diagram. Please wrap the insulated piping end to prevent water from going inside the piping.
2. If drain hose or connecting piping is in the room (where dew may form), please increase the insulation by using POLY-E FOAM with thickness 6 mm or above.

DISPOSAL OF OUTDOOR UNIT DRAIN WATER

- If a drain elbow is used, the unit should be placed on a stand which is taller than 3 cm.
- If the unit is used in an area where temperature falls below 0°C for 2 or 3 days in succession, it is recommended not to use a drain elbow, for the drain water freezes and the fan will not rotate.

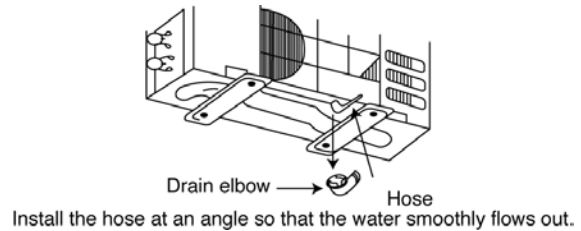

AUTO SWITCH OPERATION

The following operations can be performed by pressing the "AUTO" switch.

1. AUTO OPERATION MODE

The Auto operation will be activated immediately once the Auto Switch is pressed.
2. TEST RUN OPERATION (FOR PUMP DOWN/SERVICING PURPOSE)

The Test Run operation will be activated if the Auto Switch is pressed continuously for more than 5 sec. to below 8 sec. A "beep" sound will occur at the fifth sec., in order to identify the starting of Test Run operation.

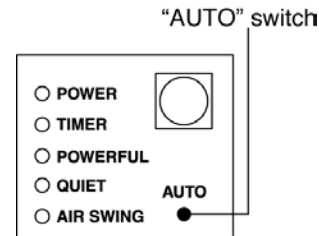

CHANGING THE REMOTE CONTROL TRANSMISSION CODE

1. Press AUTO SW continuously for 11 seconds (buzzer sound = pep pep pep)
2. After 11 seconds, release AUTO SW, then press Remo-Con TIMER "▼" SW continuously for 5 seconds. Reset code will be transmitted. After the reset code is transmitted, release TIMER "▼" SW.
3. Press Remo-Con "OFF/ON" button. The new Remo-Con No. will be accepted and memorized, after which the new Remo-Con No. can be used.

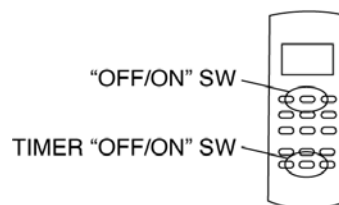

REMO-CON NO. CHANGE IN REMOTE CONTROL

1. Remove the batteries from the battery compartment of the Remote Control.
2. On the left side of the battery compartment, there is a small opening in the centre in which Jumper (J_A) can be seen. In the accepted Remo-Con PCB shown beside, Jumper (J_B) can be seen.

J_A	J_B	Remo-Con No.
Short	Open	A (Default)
Open	Open	B
Short	Short	C
Open	Short	D

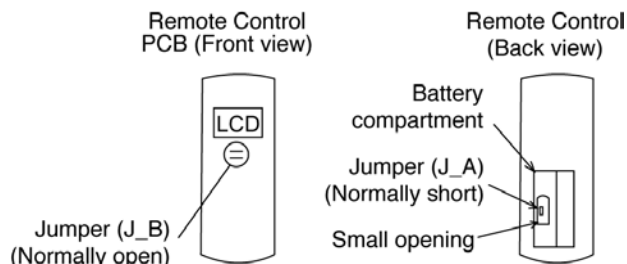

CHECK ITEMS

- | | |
|---------------------------------------------------------------------------------------------|-----------------------------------------------------------------------------------------|
| <input type="checkbox"/> Is there any gas leakage at flare nut connections? | <input type="checkbox"/> Is the cooling operation normal? |
| <input type="checkbox"/> Has the heat insulation been carried out at flare nut connections? | <input type="checkbox"/> Is the indoor unit properly secured to the installation plate? |
| <input type="checkbox"/> Is the connecting cable being fixed to the terminal board firmly? | <input type="checkbox"/> Is the power supply voltage complied with rated value? |
| <input type="checkbox"/> Is the connecting cable being clamped firmly? | <input type="checkbox"/> Is there any abnormal sound? |
| <input type="checkbox"/> Is the drainage OK? | <input type="checkbox"/> Is the thermostat operation normal? |
| <input type="checkbox"/> Is the Earth wire connection properly done? | <input type="checkbox"/> Is the remote control's LCD operation normal? |

HAND OVER

- Teach the customer the operation and maintenance procedures, using the operation manual (air filter cleaning, temperature control, etc.)

As to parts to be sold separately

- With regards to installation of the parts sold separately, follow the installation manual which is provided with the parts sold separately.

12 Servicing Information

Caution:

- Pb free solder has a higher melting point than standard solder; Typically the melting point is 50 - 70°F (30 - 40°C) higher. Please use a high temperature soldering iron. In case of the soldering iron with temperature control, please set it to 700 ± 20°F (370 ± 10°C).
- Pb free solder will tend to splash when heated too high (about 1100° F/600°C).

12.1. Troubleshooting

1. Rated Frequency Operation

During troubleshooting and servicing, rated compressor operating frequency must be obtained in order to check the specification and technical data. Below are the methods used to obtain rated compressor operating specification.

(a) Cooling

- (i) Press the Auto button continuously for 5 seconds or less than 8 seconds, the air conditioner starts operation at Cooling rated frequency. ("beep" will be heard at the 5th second.)

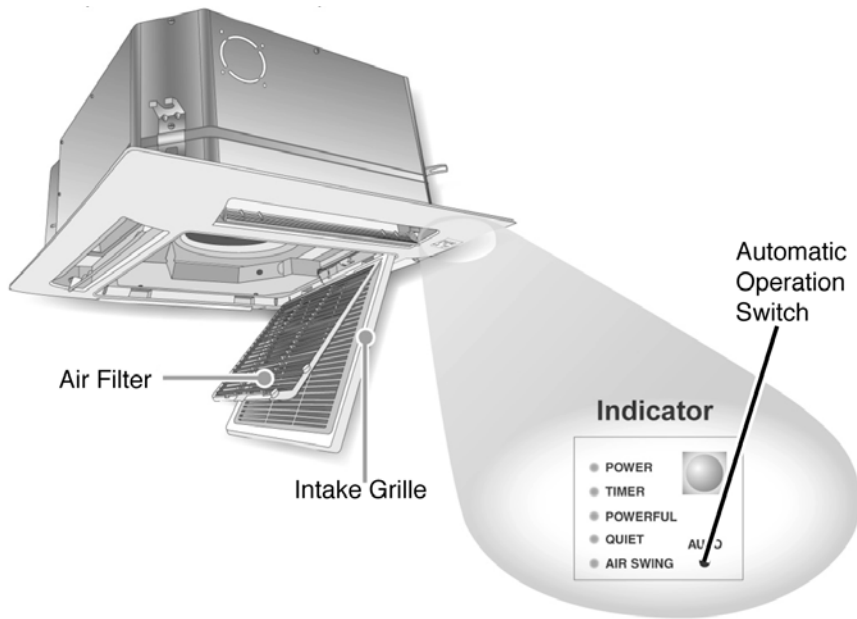

- (ii) Short the service terminal (CN-S) of the outdoor printed circuit board. The operation of air conditioner is Cooling rated frequency.

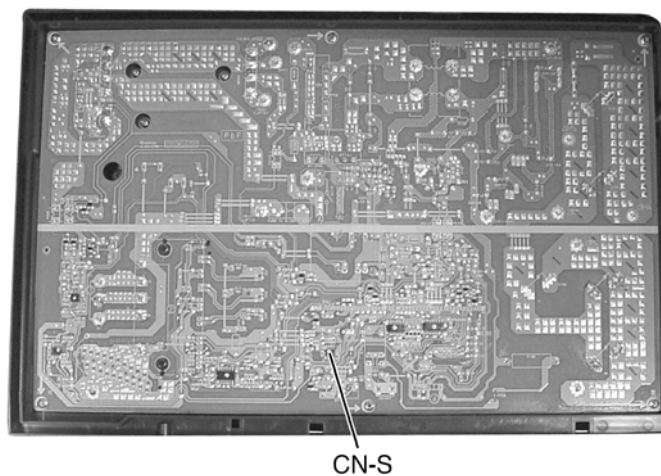

(b) Heating

Press the Auto button continuously for 8 seconds or less than 11 seconds, the air conditioner starts operation at Heating rated frequency. ("beep" "beep" will be heard at the 8th second.)

2. Troubleshooting Air Conditioner

Refrigeration cycle system

In order to diagnose malfunctions, make sure that there are no electrical problems before inspecting the refrigeration cycle. Such problems include insufficient insulation, problem with the power source, malfunction of a compressor and a fan.

The normal outlet air temperature and pressure of the refrigeration cycle depends on various conditions, the standard values for them are shown in the table to the right.

Normal Pressure and Outlet Air Temperature (Standard)

	Gas pressure MPa (kg/cm ² G)	Outlet air temperature (°C)
Cooling Mode	0.9 ~ 1.2 (9 ~ 12)	12 ~ 16
Heating Mode	2.3 ~ 2.9 (23 ~ 29)	36 ~ 45

- ★ Condition:
- Indoor fan speed; High
 - Outdoor temperature 35°C at cooling mode and 7°C at heating mode.
 - Compressor operates at rated frequency

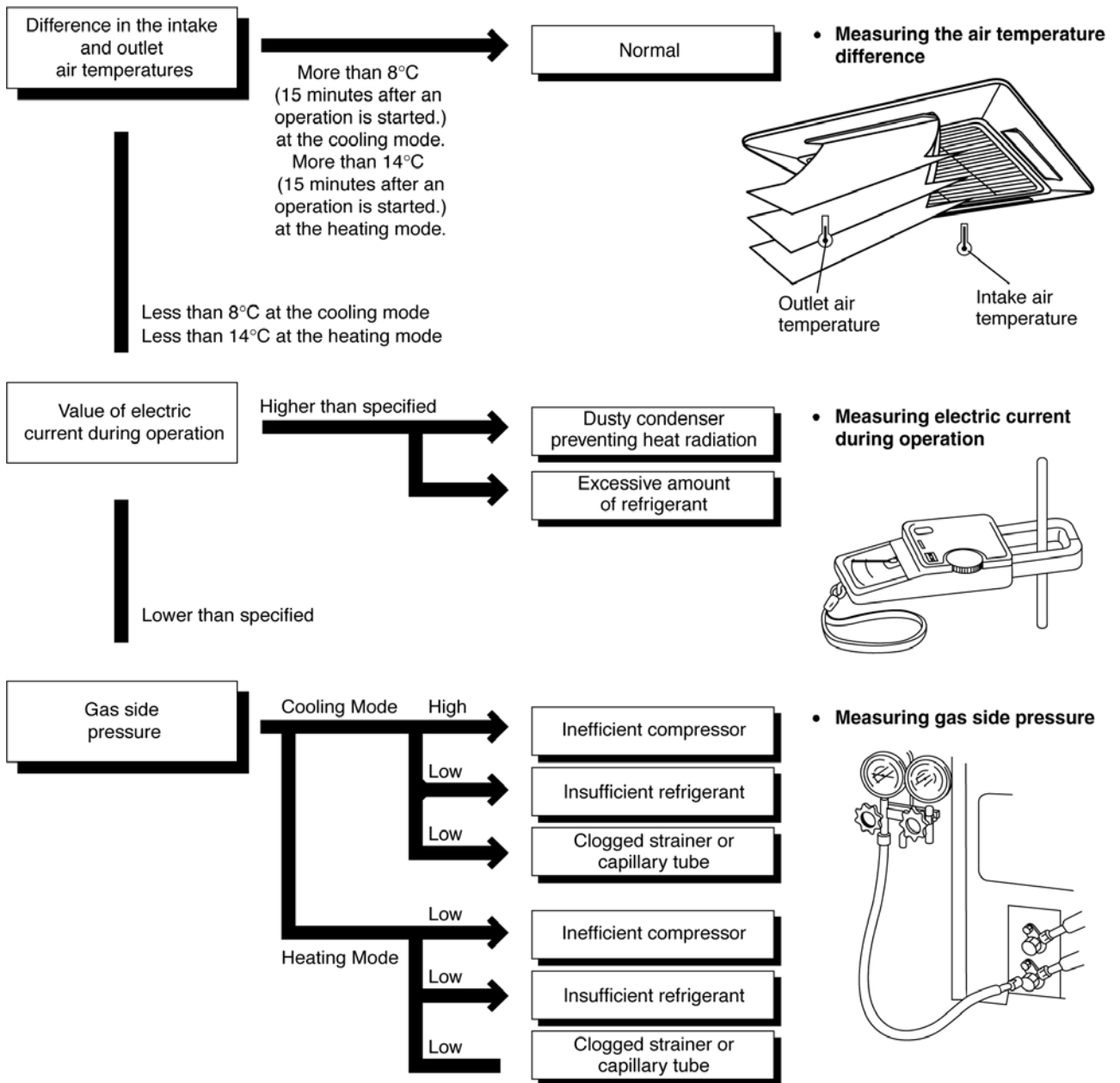

1. Relationship between the condition of the air conditioner and pressure and electric current

Condition of the air conditioner	Cooling Mode			Heating Mode		
	Low Pressure	High Pressure	Electric current during operation	Low Pressure	High Pressure	Electric current during operation
Insufficient refrigerant (gas leakage)	↘	↘	↘	↘	↘	↘
Clogged capillary tube or Strainer	↘	↘	↘	↗	↗	↗
Short circuit in the indoor unit	↘	↘	↘	↗	↗	↗
Heat radiation deficiency of the outdoor unit	↗	↗	↗	↘	↘	↘
Inefficient compression	↗	↘	↘	↗	↘	↘

- Carry on the measurements of pressure, electric current, and temperature fifteen minutes after an operation is started.

12.2. Breakdown Self Diagnosis Function

Once abnormality detected during operation, the unit will immediately stop its operation (Timer LED is blinking) and maximum of three error codes (abnormality) will be saved in memory. The abnormality of the operation can be identified through the below breakdown diagnosis method:

- Press "CHECK" button at remote control continuously for more than five seconds to turn on the diagnosis mode, "H11" will be displayed at remote control.
- By pressing the TIMER "Λ" button once, next error code will be displayed; press "V" button once, previous error code will be displayed.
- If error code displayed matches the error code saved in unit memory (abnormality detected), "beep, beep, beep...." sounds will be heard for 4 seconds and Power LED will light on. Otherwise, one "beep" sound is heard.

If "CHECK" button is press again or without any operation for 30 seconds, the diagnosis mode will turn off.

Error Codes Table

Diagnosis display	Abnormality / Protection control	Abnormality Judgement	Emergency operation	Primary location to verify
H11	Indoor / outdoor abnormal communication	> 1 min after starting operation	Indoor fan operation only	<ul style="list-style-type: none"> • Internal / external cable connections • Indoor / Outdoor PCB
H12	Connection capability rank abnormal	—	—	—
H14	Indoor intake air temperature sensor abnormality	Continue for 5 sec.	—	<ul style="list-style-type: none"> • Intake air temperature sensor (defective or disconnected)
H15	Outdoor compressor temperature sensor abnormality	Continue for 5 sec.	—	<ul style="list-style-type: none"> • Compressor temperature sensor (defective or disconnected)
H16	Outdoor Current Transformer open circuit	—	—	<ul style="list-style-type: none"> • Outdoor PCB • IPM (Power transistor) module
H19	Indoor fan motor mechanism lock	—	—	<ul style="list-style-type: none"> • Indoor PCB • Fan motor
H21	Indoor float switch operation abnormal	—	—	—
H23	Indoor heat exchanger temperature sensor abnormality	Continue for 5 sec.	O (Cooling only)	<ul style="list-style-type: none"> • Heat exchanger temperature sensor (defective or disconnected)
H27	Outdoor air temperature sensor abnormality	Continue for 5 sec.	O	<ul style="list-style-type: none"> • Outdoor temperature sensor (defective or disconnected)
H28	Outdoor heat exchanger temperature sensor abnormality	Continue for 5 sec.	O	<ul style="list-style-type: none"> • Outdoor heat exchanger temperature sensor (defective or disconnected)
H30	Discharge temperature sensor abnormality	Continue for 5 sec.	—	<ul style="list-style-type: none"> • Discharge temperature sensor
H33	Indoor/Outdoor wrong connection	—	—	<ul style="list-style-type: none"> • Indoor/Outdoor supply voltage
H35	Indoor drain water adverse current abnormal	—	—	—
H38	Indoor/Outdoor mismatch (brand code)	—	—	—
H97	Outdoor Fan Motor lock abnormality	—	—	<ul style="list-style-type: none"> • Outdoor PCB • Outdoor Fan Motor
H98	Indoor high pressure protection	—	—	<ul style="list-style-type: none"> • Air filter dirty • Air circulation short circuit
H99	Indoor heat exchanger anti-freezing protection	—	—	<ul style="list-style-type: none"> • Insufficient refrigerant • Air filter dirty
F11	Cooling / Heating cycle changeover abnormality	4 times occurrence within 30 minutes	—	<ul style="list-style-type: none"> • 4-way valve • V-coil
F90	PFC control	4 times occurrence within 10 minutes	—	<ul style="list-style-type: none"> • Voltage at PFC
F91	Refrigeration cycle abnormality	7 times occurrence continuously	—	<ul style="list-style-type: none"> • No refrigerant (3-way valve is closed)
F93	Outdoor compressor abnormal revolution	4 times occurrence within 20 minutes	—	<ul style="list-style-type: none"> • Outdoor compressor
F95	Cool high pressure protection	4 times occurrence within 20 minutes	—	<ul style="list-style-type: none"> • Outdoor refrigerant circuit
F96	IPM (power transistor) overheating protection	—	—	<ul style="list-style-type: none"> • Excess refrigerant • Improper heat radiation • IPM (Power transistor)
F97	Outdoor compressor overheating protection	4 times occurrence within 20 minutes	—	<ul style="list-style-type: none"> • Insufficient refrigerant • Compressor
F98	Total running current protection	3 times occurrence within 20 minutes	—	<ul style="list-style-type: none"> • Excess refrigerant • Improper heat radiation
F99	Outdoor Direct Current (DC) peak detection	7 times occurrence continuously	—	<ul style="list-style-type: none"> • Outdoor PCB • IPM (Power transistor) • Compressor

Note:

“O” - Frequency measured and fan speed fixed.

The memory data of error code is erased when the power supply is cut off, or press the Auto Switch until “beep” sound heard following by pressing the “RESET” button at Remote Control.

Although operation forced to stop when abnormality detected, emergency operation is possible for certain errors (refer to Error Codes Table) by using Remote Control or Auto Switch at indoor unit. However, the Remote Control signal receiving sound is changed from one “beep” to four “beep” sounds.

12.3. Remote Control

Remote Control Reset

- When the batteries are inserted for the first time or the batteries are replaced, you may notice the indications at remote control's display screen blink continuously and not functionable. If this condition happens, try to reset the remote control by pushing the reset terminal with a pointing device.
- You may also do the reset to erase the setting at remote control and restore back the default setting.

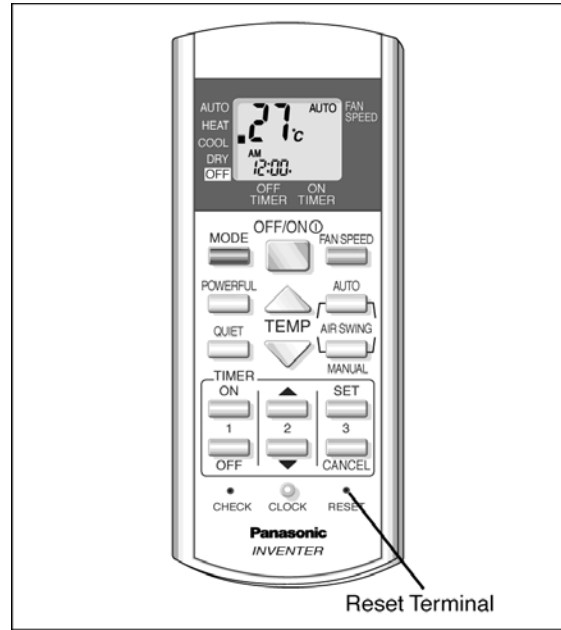

Setting Remote Control Transmission Code

- There are 4 types of remote control transmission code could be selected. The indoor unit will only operate when received signal with same transmission code from remote control. This could prevent signal interference when there are 2 or more indoor unit installed nearby together.
- To change remote control transmission code, short or open jumpers at the remote control printed circuit board.

Remote Control Printed Circuit Board	Transmission Code Combination		
	J - A	J - B	Remote Control No.
	Short	Open	A (Default)
	Open	Open	B
	Short	Short	C
	Open	Short	D

- Under various setting mode, after select the transmission code combination of remote control, press "Timer Decrement" button of remote control for 5 seconds to transmit a signal to indoor unit. The transmission code will be stored in EEPROM.
- After signal is received, the various setting mode is cancelled and return to normal operation.

12.4. Auto OFF/ON Button

- The “Auto OFF/ON” button is used to operate the air conditioner if remote control is misplaced or malfunctioning.
- Auto operation is started once “Auto OFF/ON” button is pressed.
- Forced cooling operation is possible by pressing the “Auto OFF/ON” button for more than 5 seconds where “beep” sound is heard, then release the button.

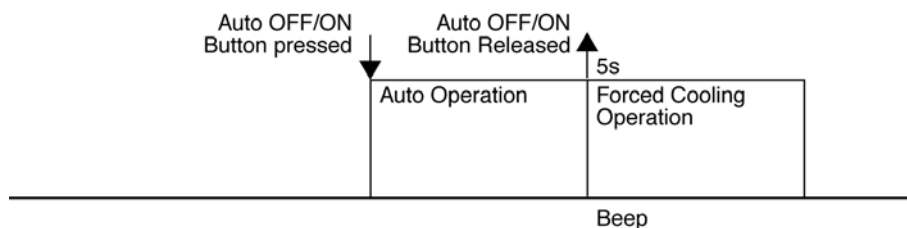

- By continuously pressing the “Auto OFF/ON” button, it will enable standby states for Forced Heating Operation, Various Setting Mode and Individual Correspondence Mode. At standby state, the unit still operates with Forced Cooling Operation.

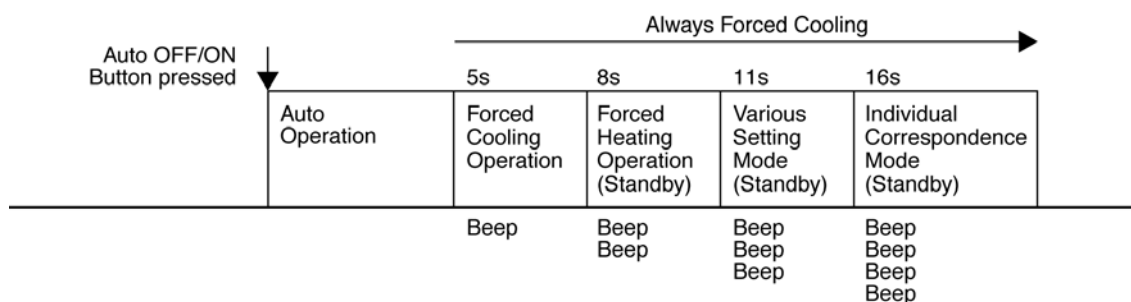

- Press “Timer Decrement” button of remote control for 5 seconds to activate the standby mode, where “beep” sound is heard.
- In Various Setting Mode, the unit captures remote control transmission code when “Check” button is pressed.
- In Individual Correspondence Mode, press “Check” button at remote control to enter remote control signal receiving sound selection mode.
Press “Auto OFF/ON” button to trigger the remote control signal receiving sound.
 - Short “Beep”: Turn OFF remote control signal receiving sound.
 - Long “Beep”: Turn ON remote control signal receiving sound.
- After signal is received, the unit returns to normal operation.

12.5. Disassembly of Parts

1. Open the Intake Grille from the Front Grille by moving the catchers to center (Fig. 1).



Fig. 1

2. Remove the Control Board Cover by removing the screws (Fig. 2).

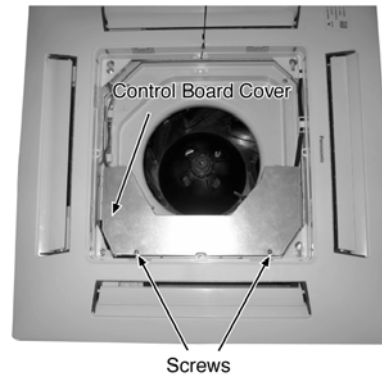

Fig. 2

3. Release the (Fig. 3):

- CN-STM1 (WHT) connector.
- CN-STM2 (YLW) connector.
- CN-DISP (WHT) connector.
- CN-FM (WHT) connector.
- CN-TH1 (WHT) connector.
- CN-TH2 (BLU) connector.
- CN-DRMTR1 (BLU) connector.
- AC01 (BLK), AC02 (WHT) and CN-DRMTR2 (RED) from Terminal Board.
- G01 (GRN) screw.
- Two T-BLK connectors.
- CN-T1 (WHT).
- CN-T2 (YLW).

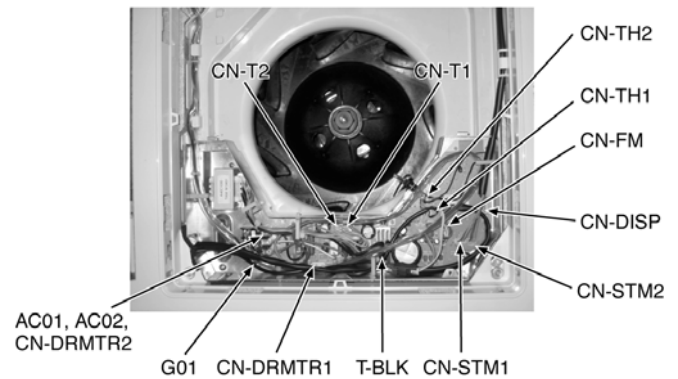

Fig. 3

4. To remove the Electronic Controller, release the 6 hooks that hold it to the Control Board (Fig. 4).

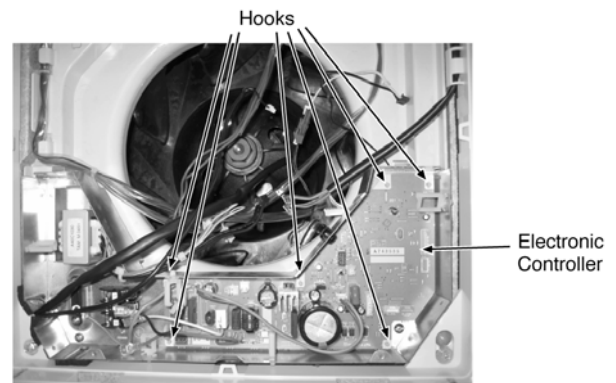

Fig. 4

5. Remove the Front Grille by removing the screw A and screws B, C & D half way open (Fig. 5).

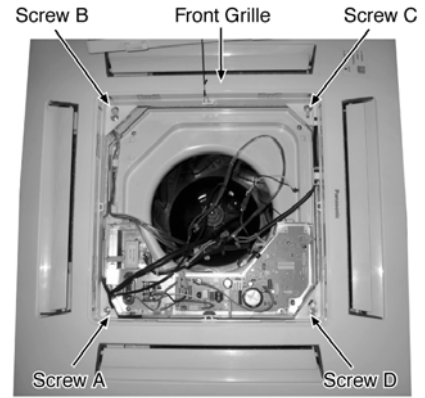

Fig. 5

6. Remove the Air Guider and Drain Pan complete by removing the screws (Fig. 6).

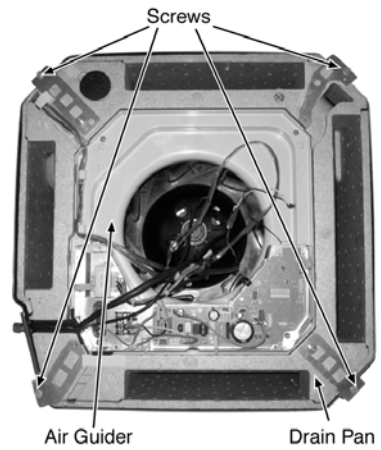

Fig. 6

7. Remove the Turbo Fan by removing the bolt (Fig. 7).

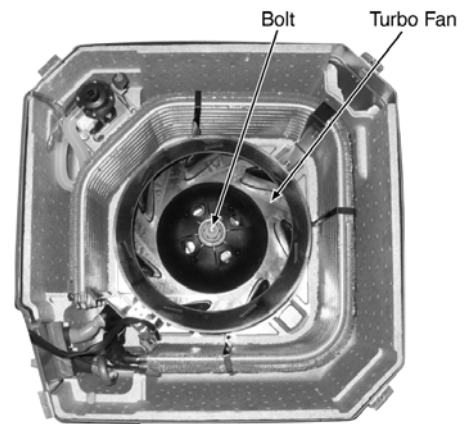

Fig. 7

8. Remove the Fan Motor by release the Fan Motor lead wire connectors and Fan Motor screws (Fig. 8).

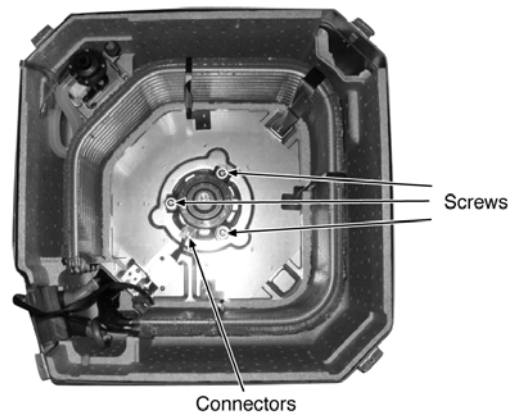

Fig. 8

Outdoor Electronic Controller Removal Procedure

1. Remove the top panel and front panel

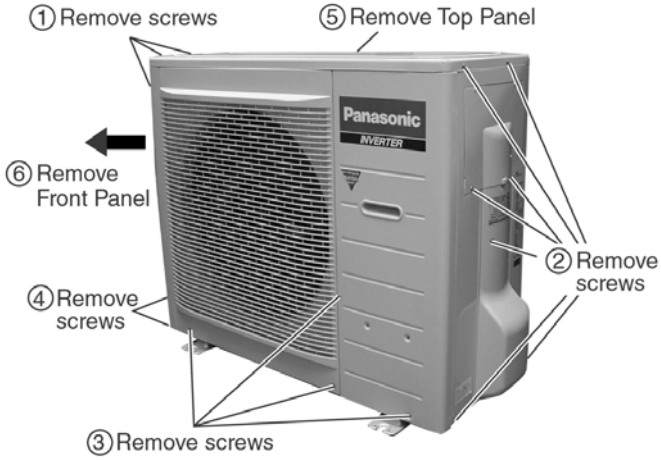

Fig. 9

2. Remove the Outdoor Electronic Controller



Fig. 10

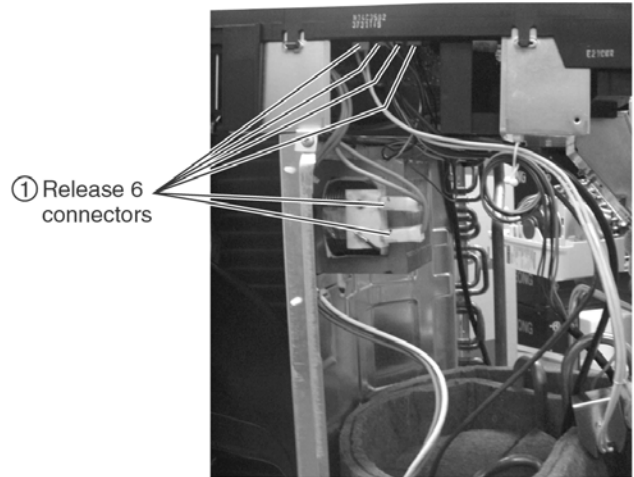

Fig. 11

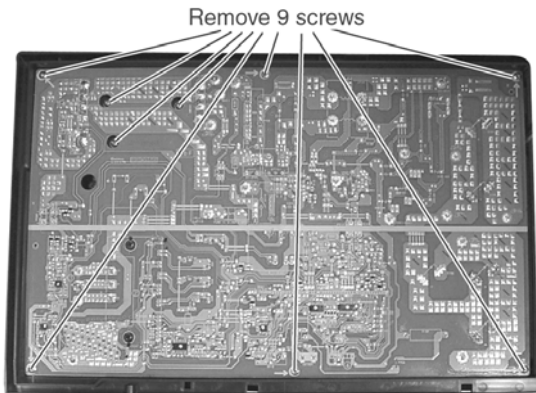



Fig. 12

WARNING

- Be save to return the wiring to its original position
- There are many high voltage components within the heat sink cover so never touch the interior during operation. Wait at least two minutes after power has been turned off.

 Caution! When handling electronic controller, be careful of electrostatic discharge.

13 Technical Data

13.1. Operation Characteristics

13.1.1. CS-E15DB4EW CU-E15DBE

• Cooling Characteristic

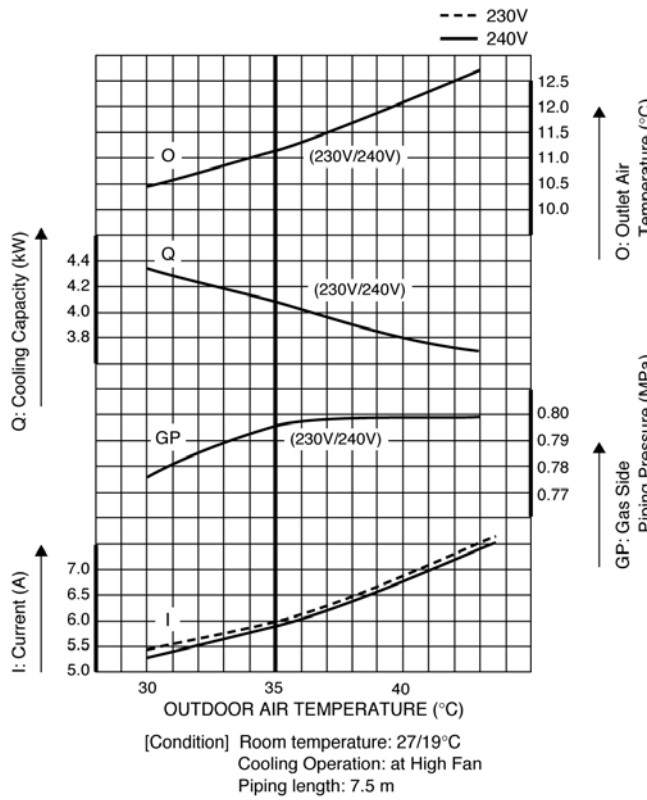

• Piping Length Characteristic (Cooling)

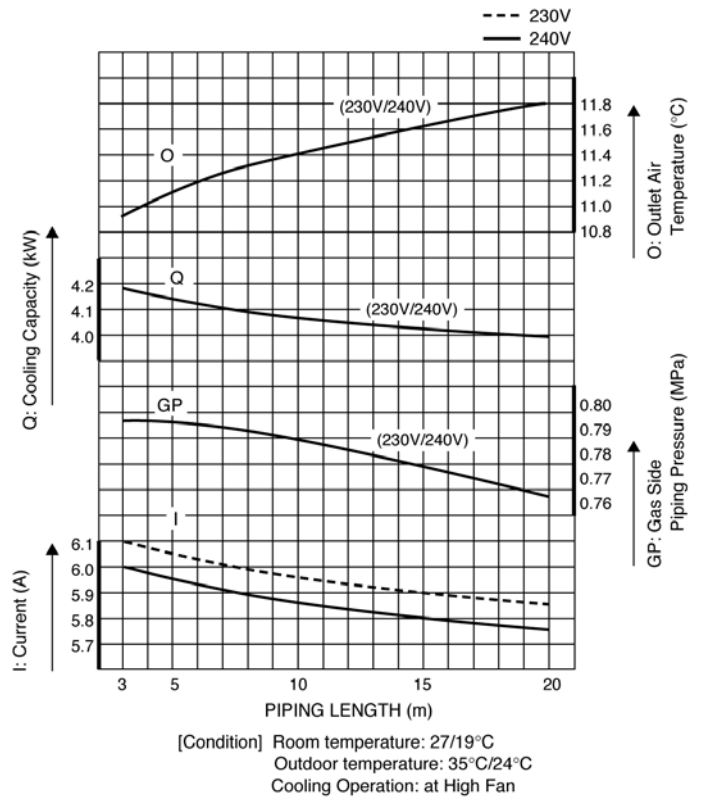

• Heating Characteristic

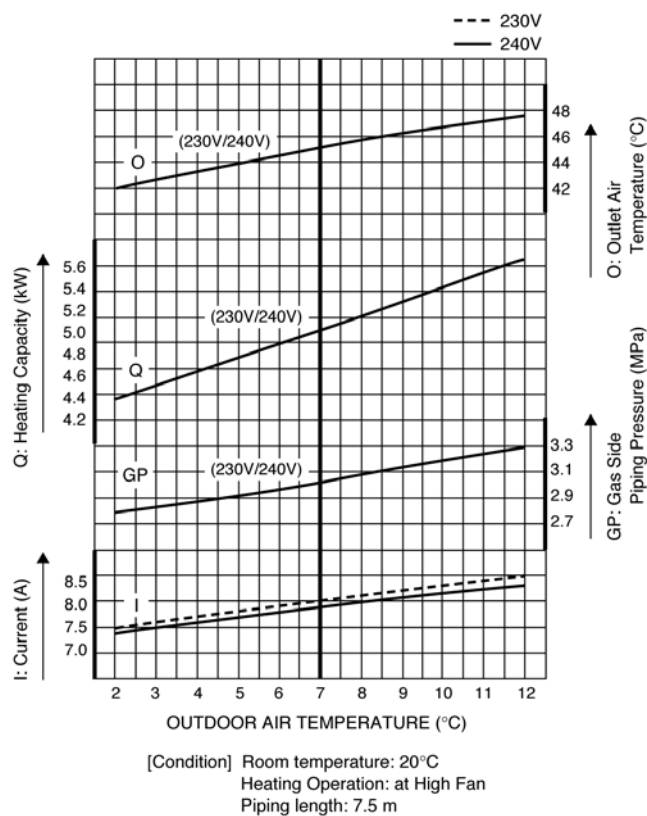

• Piping Length Characteristic (Heating)

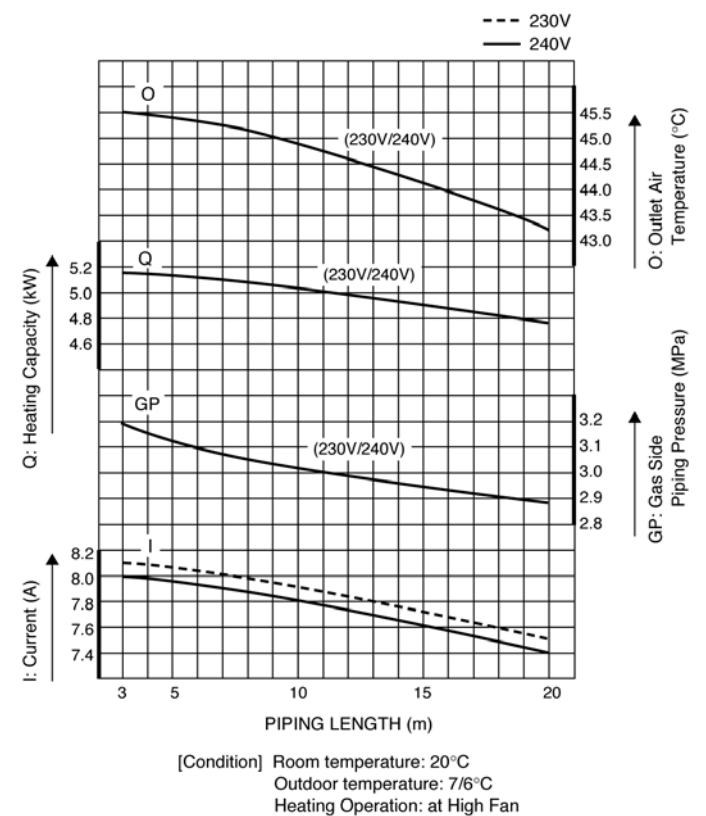

13.1.2. CS-E18DB4EW CU-E18DBE

• Cooling Characteristic

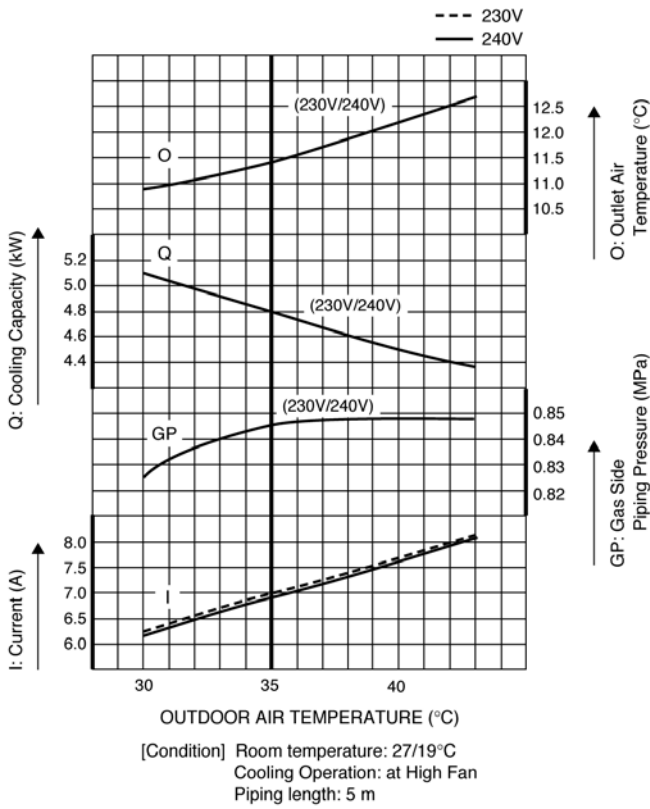

• Piping Length Characteristic (Cooling)

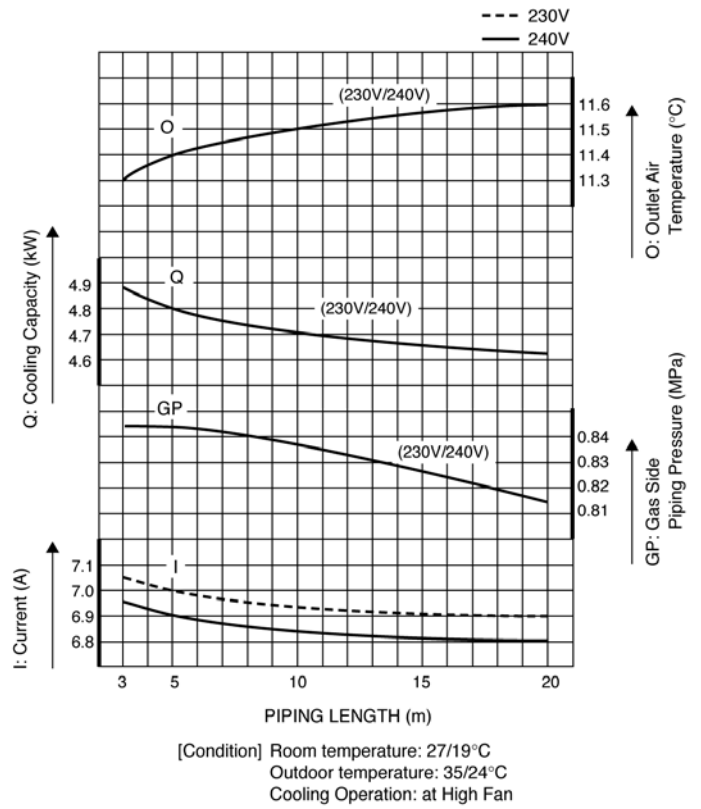

• Heating Characteristic

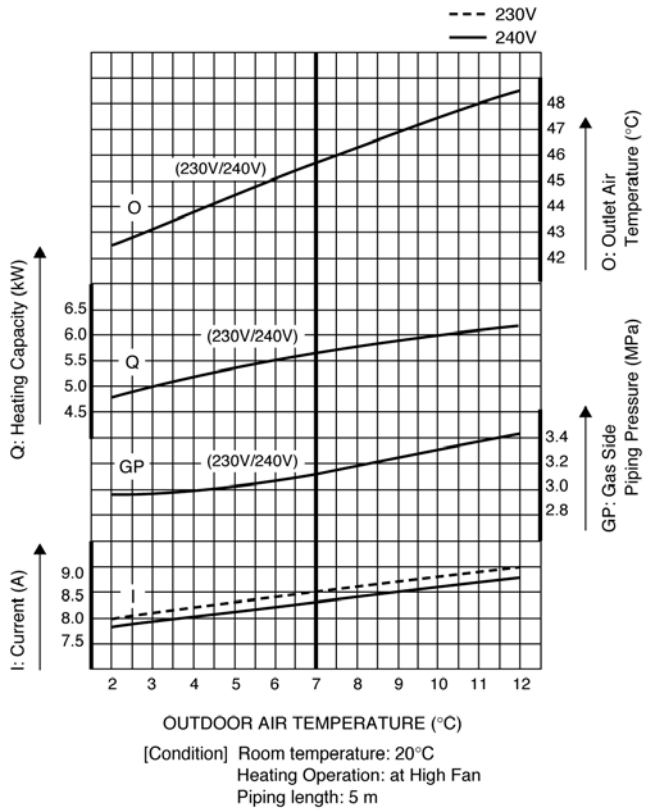

• Piping Length Characteristic (Heating)

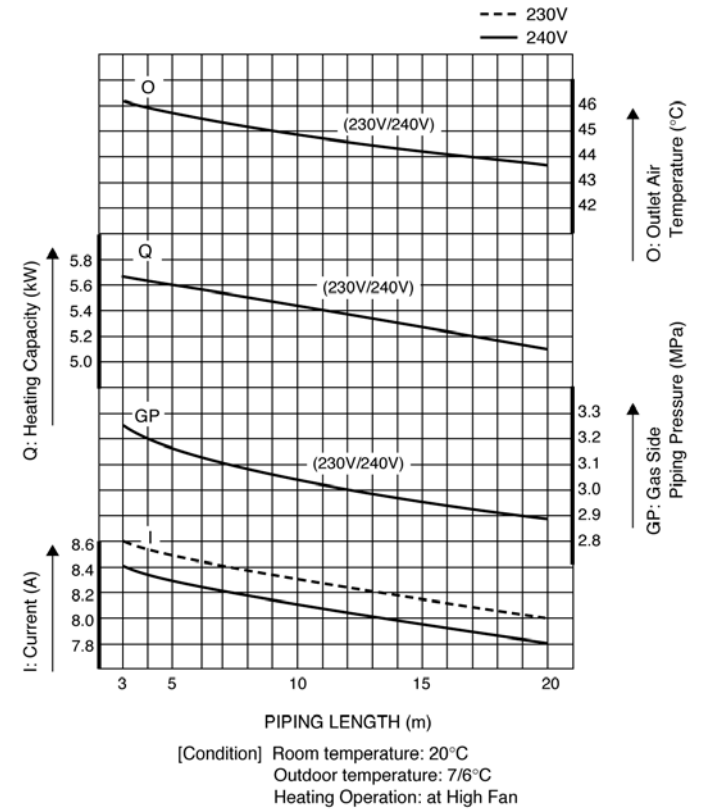

13.1.3. CS-E21DB4ES CU-E21DBE

• Cooling Characteristic

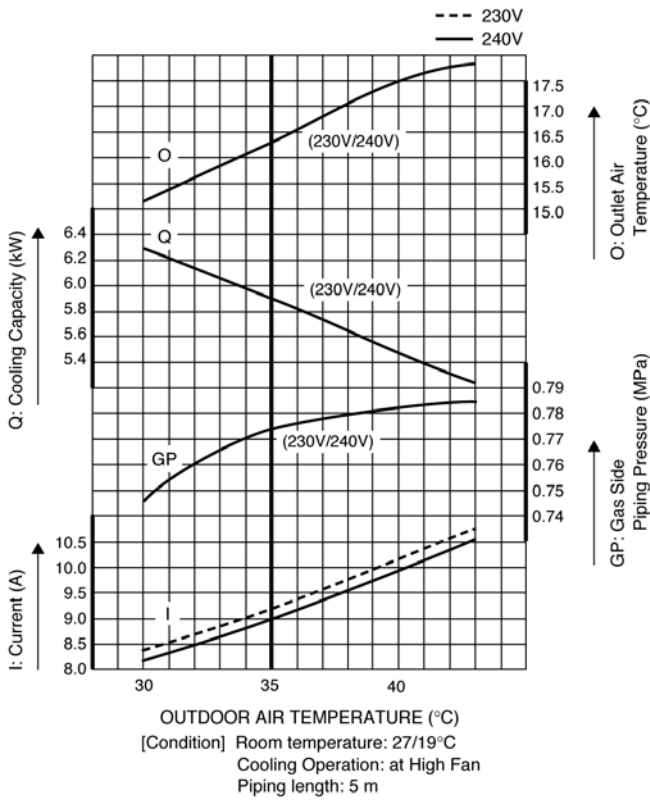

• Piping Length Characteristic (Cooling)

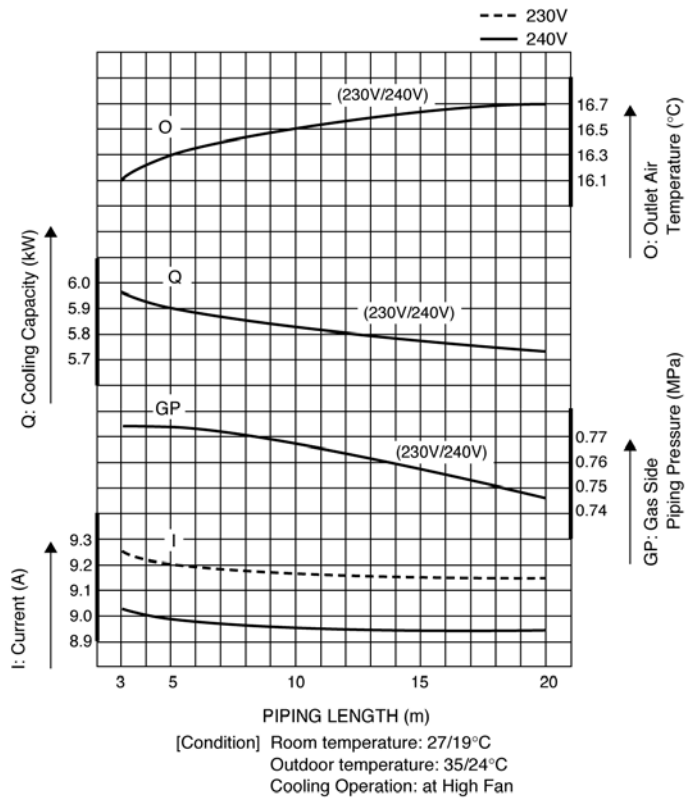

• Heating Characteristic

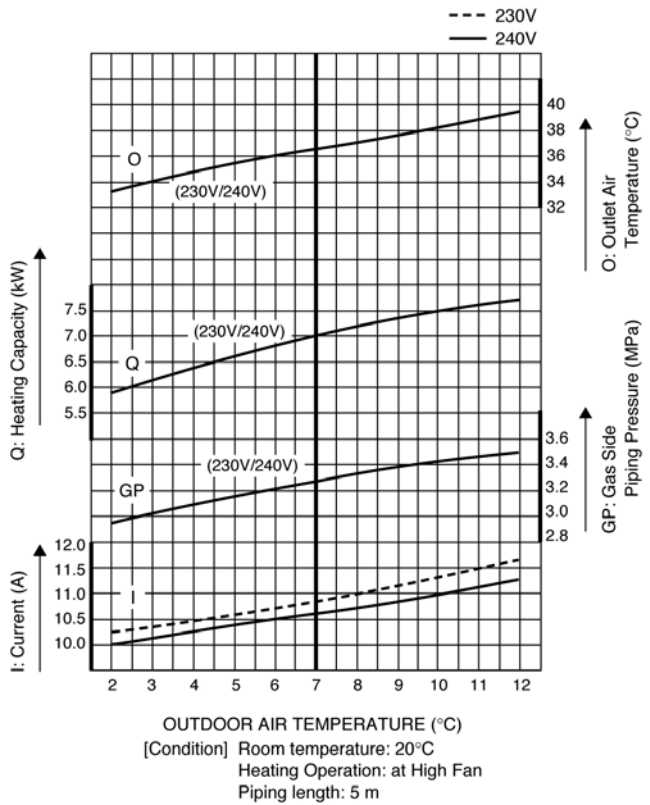

• Piping Length Characteristic (Heating)

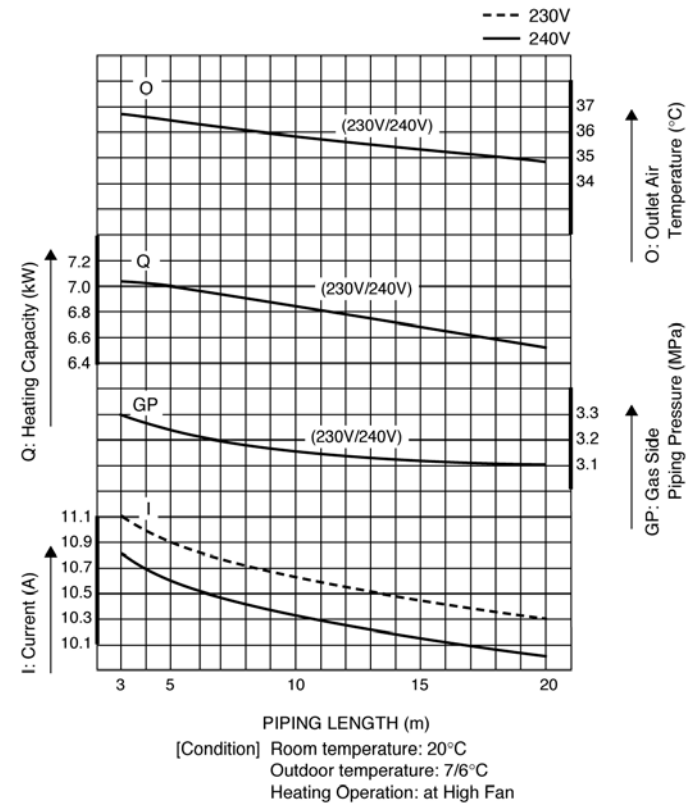

13.2. Sensible Capacity Chart

● CS-E15DB4EW CU-E15DBE

Indoor wet bulb temp.	Outdoor Temp. (°C)											
	30			35			40			46		
	TC	SHC	IP	TC	SHC	IP	TC	SHC	IP	TC	SHC	IP
17.0°C	4.07	3.08	1.19	3.80	2.96	1.28	3.53	2.84	1.37	3.21	2.70	1.48
19.0°C				4.10		1.30						
19.5°C	4.46	3.23	1.21	4.17	3.10	1.31	3.88	2.99	1.40	3.53	2.84	1.51
22.0°C	4.87	3.35	1.24	4.55	3.22	1.33	4.23	3.11	1.42	3.85	2.96	1.53

● CS-E18DB4EW CU-E18DBE

Indoor wet bulb temp.	Outdoor Temp. (°C)											
	30			35			40			46		
	TC	SHC	IP	TC	SHC	IP	TC	SHC	IP	TC	SHC	IP
17.0°C	4.76	3.61	1.40	4.45	3.46	1.51	4.14	3.33	1.61	3.76	3.16	1.74
19.0°C				4.80		1.53						
19.5°C	5.23	3.78	1.43	4.89	3.63	1.54	4.55	3.50	1.64	4.13	3.33	1.77
22.0°C	5.70	3.92	1.45	5.32	3.77	1.56	4.95	3.64	1.67	4.50	3.47	1.80

● CS-E21DB4ES CU-E21DBE

Indoor wet bulb temp.	Outdoor Temp. (°C)											
	30			35			40			46		
	TC	SHC	IP	TC	SHC	IP	TC	SHC	IP	TC	SHC	IP
17.0°C	5.85	4.44	1.88	5.47	4.26	2.02	5.09	4.09	2.16	4.63	3.89	2.33
19.0°C				5.90		2.05						
19.5°C	6.43	4.65	1.91	6.01	4.46	2.06	5.59	4.30	2.20	5.08	4.09	2.37
22.0°C	7.00	4.82	1.95	6.54	4.63	2.10	6.09	4.47	2.24	5.53	4.26	2.42

TC - Total Cooling Capacity (kW)
 SHC - Sensible Heat Capacity (kW)
 IP - Input Power (kW)

Indoor 27°C/19°C
 Outdoor 35°C/24°C

14 Exploded View (Indoor Unit)

14.1. CS-E15DB4EW CS-E18DB4EW CS-E21DB4ES

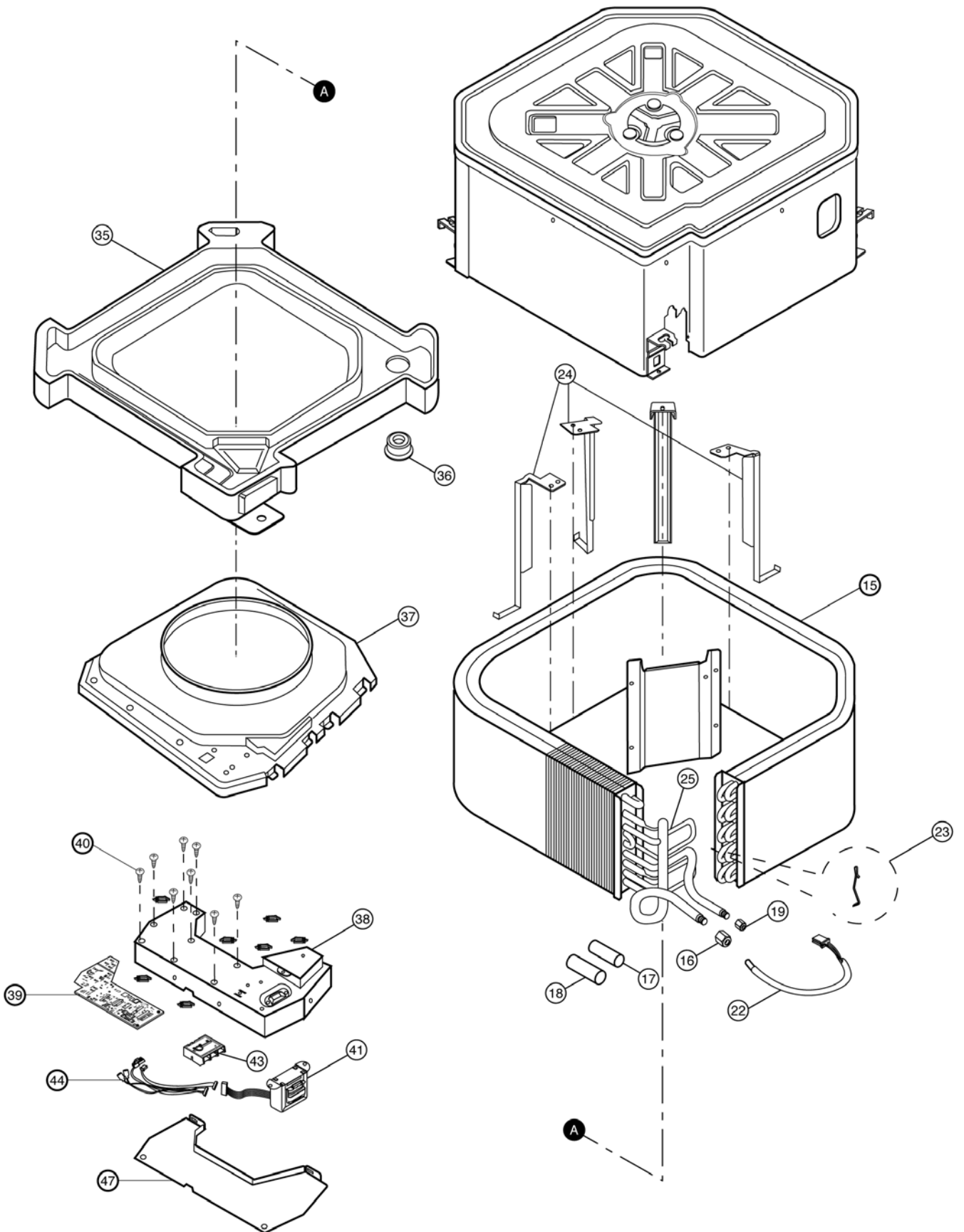

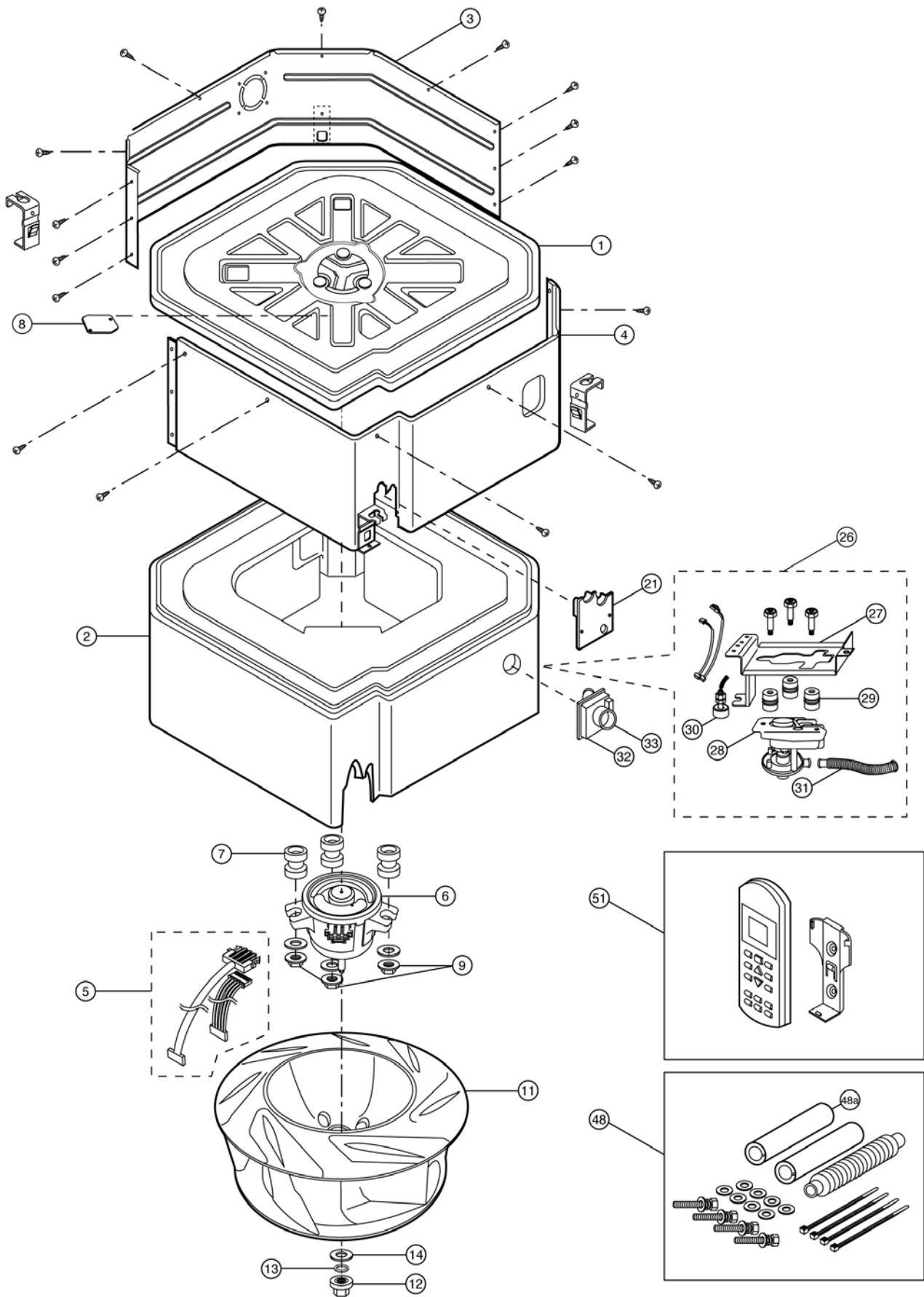

Note:

The above exploded view is for the purpose of parts disassembly and replacement.
 The non-numbered parts are not kept as standard service parts.

14.2. CZ-BT20E (Front Grille Complete)

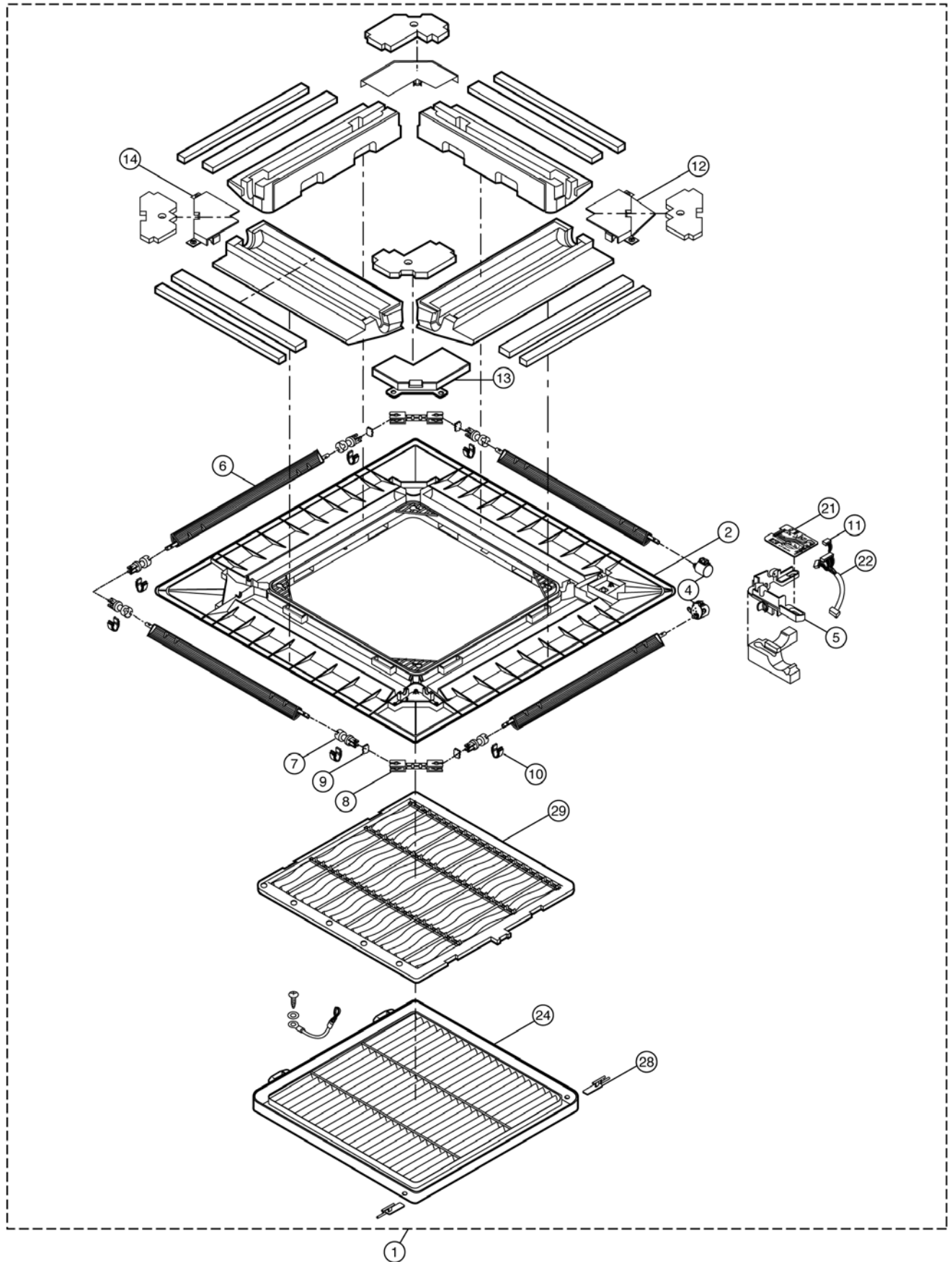

Note:

The above exploded view is for the purpose of parts disassembly and replacement.

The non-numbered parts are not kept as standard service parts.

15 Replacement Parts List (Indoor Unit)

15.1. CS-E15DB4EW CS-E18DB4EW CS-E21DB4ES

REF. NO.	PARTS NAME & DESCRIPTION	QTY	CS-E15DB4EW	CS-E18DB4EW	CS-E21DB4ES	REMARKS
1	BASE PAN ASS'Y	1	CWD52K1100	←	←	
2	INNER POLYSTYRENE COMPLETE	1	CWG07C1047	←	←	
3	CABINET SIDE PLATE ASS'Y	1	CWE041121	←	←	
4	CABINET SIDE PLATE ASS'Y	1	CWE041122	←	←	
5	LEAD WIRE - FAN MOTOR	1	CWA67C5136	←	←	
6	FAN MOTOR	1	EHDS50A40AC	←	←	O
7	ANTI - VIBRATION BUSHING	3	CWH501065	←	←	
8	CORD HOLDER	1	CWD741024	←	←	
9	SCREW - FAN MOTOR	3	CWH7080300	←	←	
11	TURBO FAN	1	CWH03K1022	←	←	
12	NUT for TURBO FAN	1	CWH561042	←	←	
13	SP WASHER	1	XWA8	←	←	
14	WASHER	1	XWG8H22	←	←	
15	EVAPORATOR COMPLETE	1	CWB30C1668	←	CWB30C1526	
16	FLARE NUT (1/2")	1	CWT251032	←	←	
17	HEATPROOF TUBE	1	CWG021024	←	←	
18	HEATPROOF TUBE	1	CWG021064	←	←	
19	FLARE NUT (1/4")	1	CWT251030	←	←	
21	PIPE COVER	1	CWD93C1050	←	←	
22	SENSOR - EVAPORATOR	1	CWA50C2274	←	←	
23	HOLD SENSOR	1	CWH32143	←	←	
24	EVAPORATOR SUPPORTER	3	CWD911529A	←	←	
25	TUBE ASS'Y (CAPIL. TUBE)	1	CWT07K1188	←	←	
26	DRAIN PUMP COMPLETE	1	CWB53C1015	←	←	
27	PANEL DRAIN PUMP ASS'Y	1	CWD93K1008	←	←	
28	DRAIN PUMP	1	CWB532043	←	←	
29	ANTI - VIBRATION BUSHING	3	CWH501080	←	←	
30	FLOAT SWITCH - DRAIN PUMP	1	CWA121215	←	←	
31	FLEXIBLE PIPE	1	CWH85C1033	←	←	
32	DRAIN NOZZLE	1	CWH411011	←	←	
33	DRAIN HOSE HEAT INSULATION	1	CWG321050	←	←	
35	DRAIN PAN - COMPLETE	1	CWH40C1034	←	←	
36	DRAIN PLUG	1	CWB821008	←	←	
37	AIR GUIDER BLOWER WHEEL	1	CWD321058	←	←	
38	CONTROL BOARD CASING	1	CWH10K1048	←	←	
39	ELECTRONIC CONTROLLER (MAIN)	1	CWA73C1778	CWA73C1779	CWA73C1780	O
40	SPACER	6	CWH541026	←	←	
41	TRANSFORMER	1	CWA40C1030	←	←	
43	TERMINAL BOARD - (3 PIN)	1	CWA28K1076	←	←	O
44	LEADWIRE-AIR TEMP. SENSOR	1	CWA67C5139	←	←	O
47	CONTROL BOARD COVER	1	CWH13C1100	←	←	
48	ACCESSORY COMPLETE	1	CWH82C1270	←	←	
48A	HEATPROOF TUBE	1	CWG021025	←	←	
51	WIRELESS REMOTE CONTROL COMPLETE	1	CWA75C2610	←	←	O

(Note)

- All parts are supplied from PHAAM, Malaysia (Vendor Code: 061).
- "O" marked parts are recommended to be kept in stock.

15.2. CZ-BT20E (Front Grille Complete)

REF. NO.	PART DESCRIPTION	QTY	PART NO.
1	FRONT GRILLE - COMPLETE	1	CWE11C3105
2	FRONE - FRONT GRILLE CO.	1	CWE11C3353
4	A.S MOTOR DC SINGLE 12V 250 OHM	2	CWA981105
5	BRACKET - A.S.MOTOR	1	CWD932522
6	VANE	4	CWE241159
7	SHAFT	6	CWH631038
8	SHAFT	2	CWH631045
9	CONNECTOR - SHAFT	4	CWH081007
10	BEARING	6	CWH641008
11	LEAD WIRE - A.S.MOTOR	1	CWA67C5117
12	PLATE COVER FOR A.S.MOTOR	1	CWD911459
13	PLATE COVER FOR CONNECTING SHAFT	2	CWD911460
14	PLATE COVER FOR END SHAFT	1	CWD911461
21	ELECTRONIC CONT. (RECEIVER & INDICATOR)	1	CWA743610
22	LEAD WIRE - COMPLETE	1	CWA67C5576
24	INTAKE GRILLE	1	CWE221131
28	LEVER ARM	2	CWH651029
29	AIR FILTER	1	CWD001142

(Note)

- All parts are supplied from PHAAM, Malaysia (Vendor Code: 061).
- "O" marked parts are recommended to be kept in stock.

16 Exploded View (Outdoor Unit)

16.1. CU-E15DBE CU-E18DBE CU-E21DBE

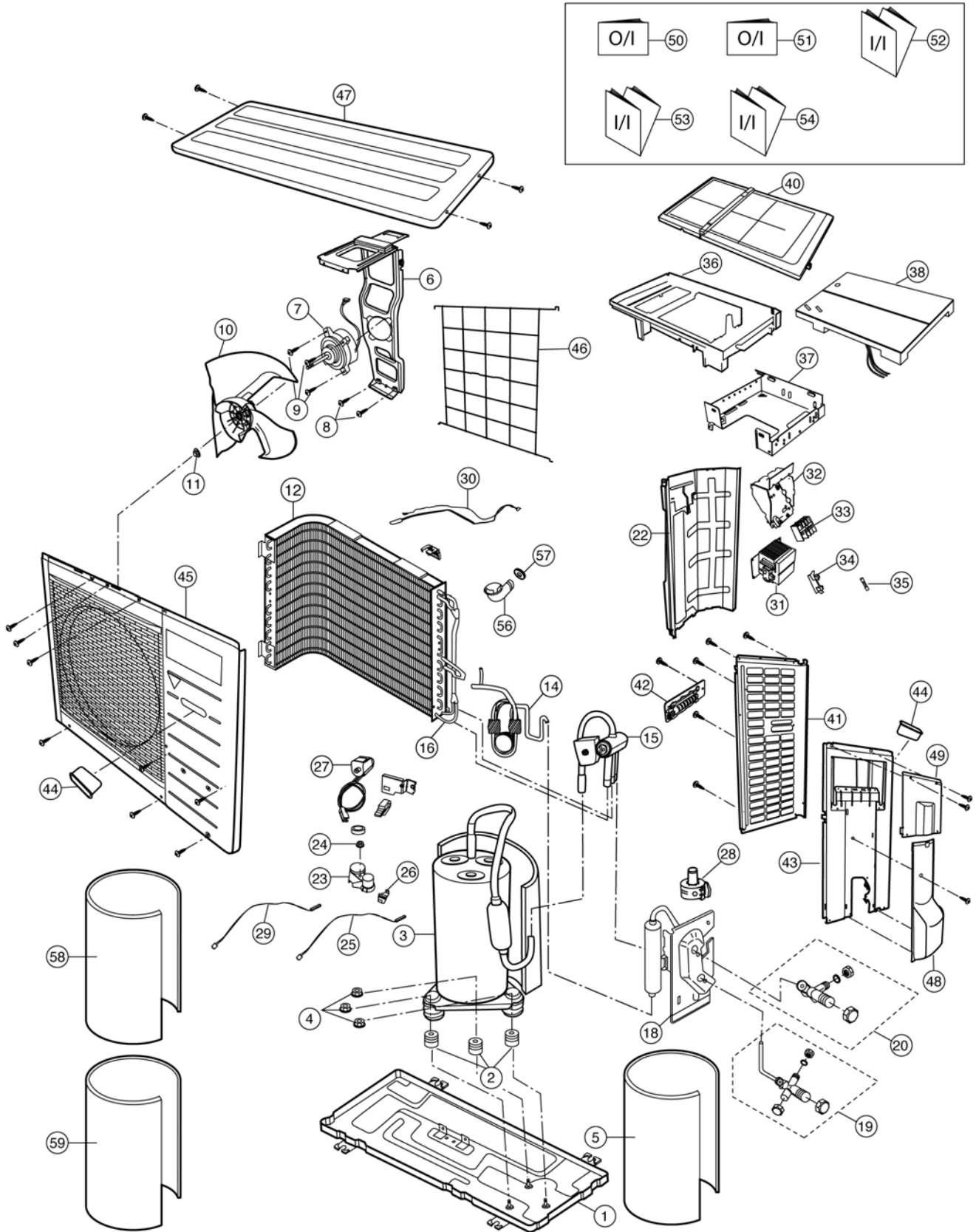

Note:
 The above exploded view is for the purpose of parts disassembly and replacement.
 The non-numbered parts are not kept as standard service parts.

17 Replacement Parts List (Outdoor Unit)

17.1. CU-E15DBE CU-E18DBE CU-E21DBE

REF NO.	DESCRIPTION & NAME	QTY.	CU-E15DBE	CU-E18DBE	CU-E21DBE	REMARKS
1	CHASSY ASSY	1	CWD50K2085	←	←	
2	ANTI-VIBRATION BUSHING	3	CWH50077	←	←	
3	COMPRESSOR	1	5CS130XAD04	←	←	O
4	NUT-COMPRESSOR MOUNT	3	CWH56000	←	←	
5	SOUND PROOF MATERIAL	1	CWG302302	←	←	
6	FAN MOTOR BRACKET	1	CWD541084	CWD541054	←	
7	FAN MOTOR	1	CWA981166	←	←	O
8	SCREW - FAN MOTOR BRACKET	2	CWH551060	←	←	
9	SCREW - FAN MOTOR MOUNT	3	CWH551106	←	←	
10	PROPELLER FAN ASSY	1	CWH03K1016	←	←	
11	NUT - PROPELLER FAN	1	CWH56053	←	←	
12	CONDENSER	1	CWB32C1583	CWB32C1527	CWB32C1526	
14	TUBE ASS'Y COMPLETE (CAP TUBE/EXP.VALVE)	1	CWT023679	←	CWT023610	O
15	4 WAYS VALVE	1	CWB001026	←	←	
16	STRAINER	1	CWB11094	←	←	
18	HOLDER - COUPLING	1	CWH351035	←	←	
19	3 WAYS VALVE (GAS)	1	CWB011170	←	←	O
20	2 WAYS VALVE (LIQUID)	1	CWB021292	←	CWB021306	O
22	SOUND PROOF BOARD	1	CWH151050	←	←	
23	TERMINAL COVER	1	CWH171001	←	←	
24	NUT-TERMINAL COVER	1	CWH7080300	←	←	
25	SENSOR COMPLETE (COMP. TOP)	1	CWA50C2185	←	←	
26	HOLDER SENSOR	1	CWH321010	←	←	
27	V-COIL COMPLETE (4-WAYS VALVE)	1	CWA43C2168	←	←	
28	V-COIL COMPLETE (EXPAND VALVE)	1	CWA43C2141	←	←	
29	SENSOR COMPLETE (COMP. DISC.)	1	CWA50C2180	←	←	
30	SENSOR COMPLETE	1	CWA50C2181	←	←	
31	REACTOR	1	CWA421069	←	←	
32	CONTROL BOARD CASING (SIDE)	1	CWH102273	←	←	
33	TERMINAL BOARD ASSY	1	CWA28K1110	←	←	
34	FUSE HOLDERS	1	K3GB1PH00016	←	←	
35	FUSE	1	K5D303BBA002	←	←	
36	CONTROL BOARD CASING (TOP)	1	CWH102204	←	←	
37	CONTROL BOARD CASING (BOTTOM)	1	CWH102282	←	←	
38	ELECTRONIC CONTROLLER - MAIN	1	CWA73C1767R	CWA73C1768R	CWA73C1769R	O
40	CONTROL BOARD COVER (TOP)	1	CWH131167	←	←	
41	CABINET SIDE PLATE (LEFT)	1	CWE041082A	←	←	
42	HANDLE	1	CWE161010	←	←	
43	CABINET SIDE PLATE (RIGHT)	1	CWE041083A	←	←	
44	HANDLE	2	CWE16000E	←	←	
45	CABINET FRONT PLATE CO.	1	CWE06K1043	←	←	
46	WIRE NET	1	CWD041041A	←	←	
47	CABINET TOP PLATE	1	CWE031031A	←	←	
48	CONTROL BOARD COVER (BOTTOM)	1	CWH131168	←	←	
49	CONTROL BOARD COVER (TOP)	1	CWH131169A	←	←	
50	OPERATING INSTRUCTION	1	CWF564379	←	←	
51	OPERATING INSTRUCTION	1	CWF564380	←	←	
52	INSTALLATION INSTRUCTION	1	CWF612604	←	←	
53	INSTALLATION INSTRUCTION	1	CWF612605	←	←	
54	INSTALLATION INSTRUCTION	1	CWF612606	←	←	
56	DRAIN HOSE	1	CWH5850080	←	←	
57	PACKING	1	CWB81012	←	←	
58	SOUND PROOF MATERIAL	1	CWG302290	CWG302270	←	
59	SOUND PROOF MATERIAL	1	CWG302301	CWG302300	←	

(Note)

- All parts are supplied from PHAAM, Malaysia (Vendor Code: 061).
- "O" marked parts are recommended to be kept in stock.

18 Electronic Circuit Diagram

18.1. Indoor Unit

● CS-E15DB4EW CS-E18DB4EW CS-E21DB4ES

SCHEMATIC DIAGRAM 1/4

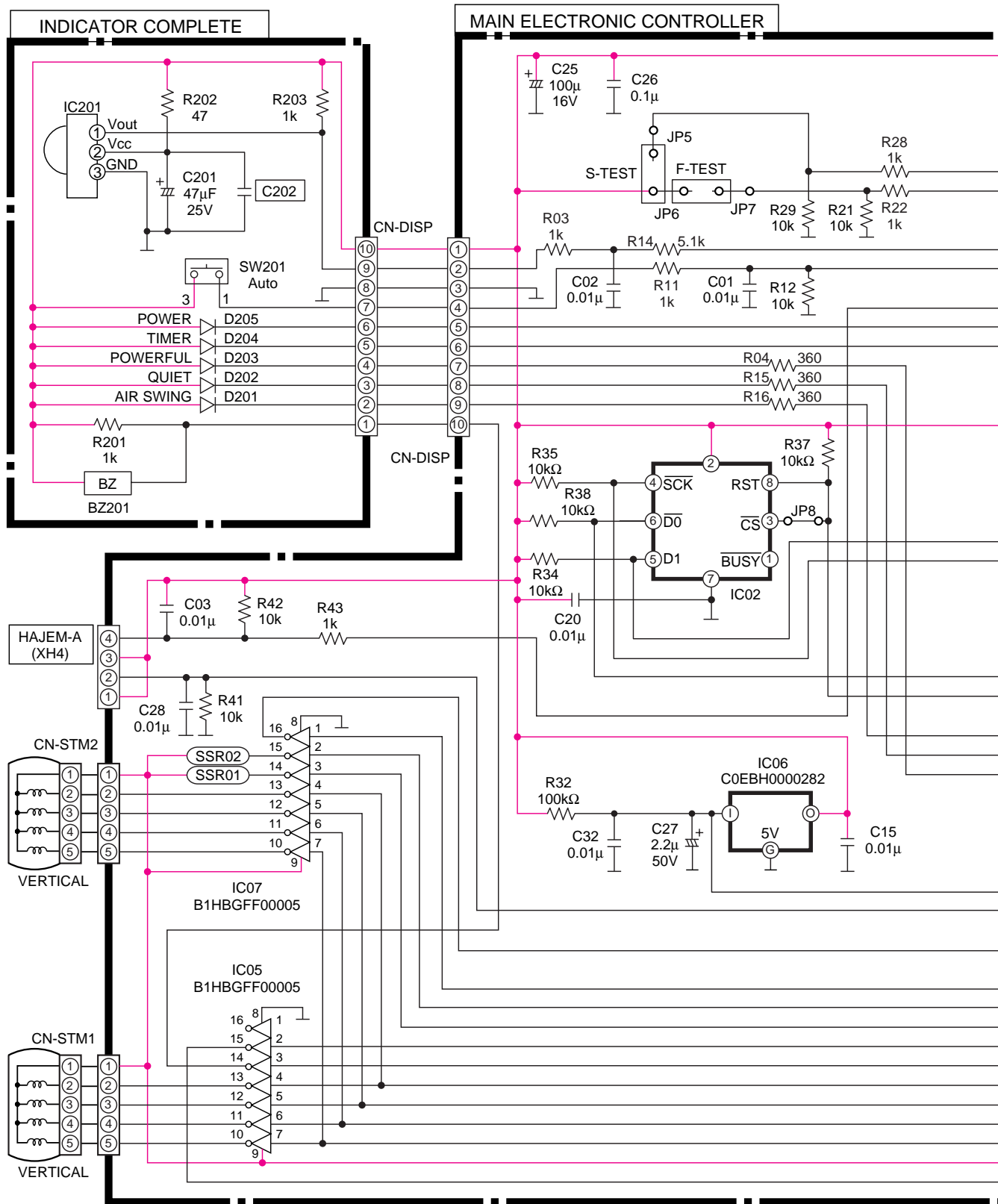

SCHEMATIC DIAGRAM 2/4

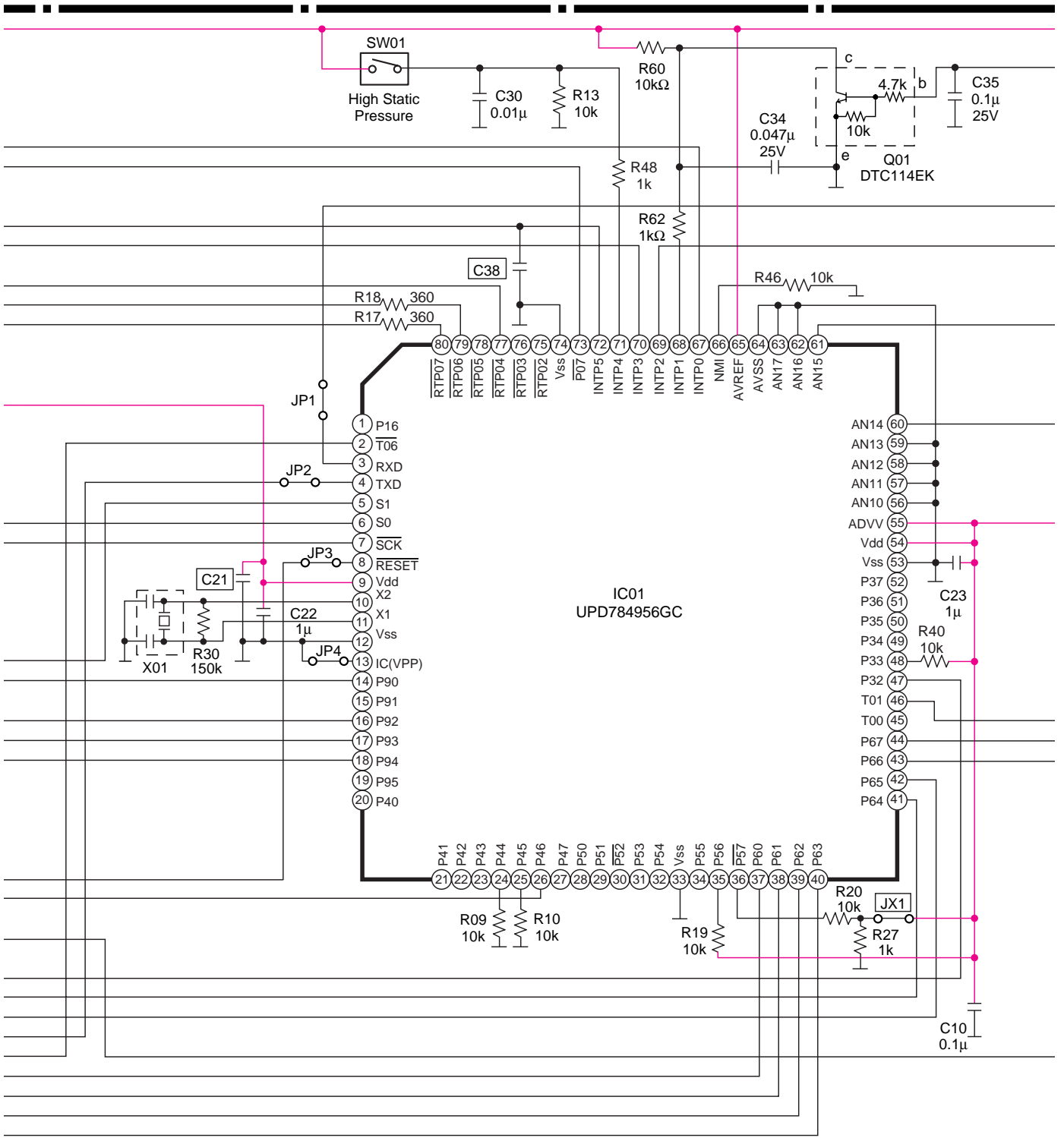

SCHEMATIC DIAGRAM 3/4

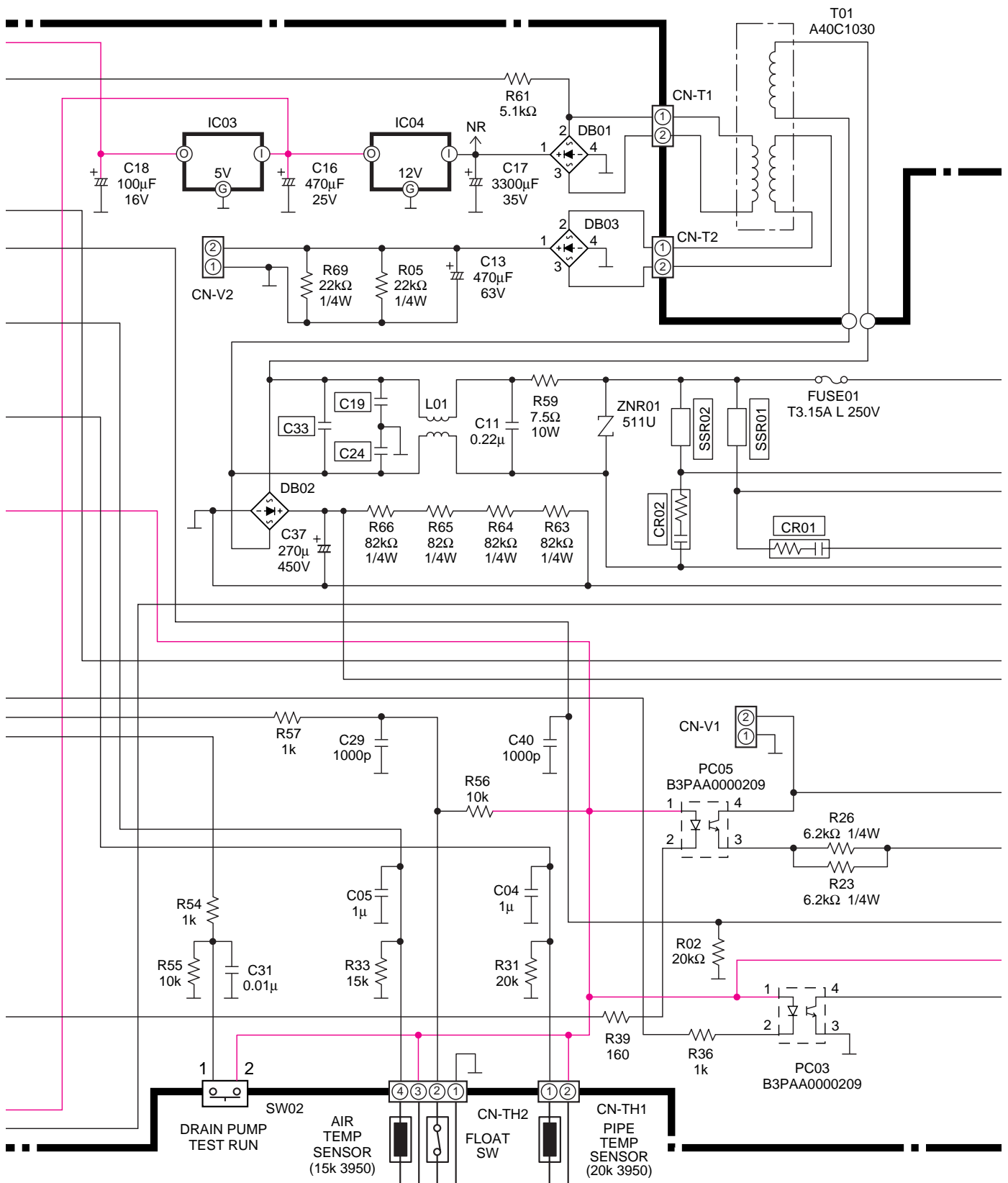

SCHEMATIC DIAGRAM 4/4

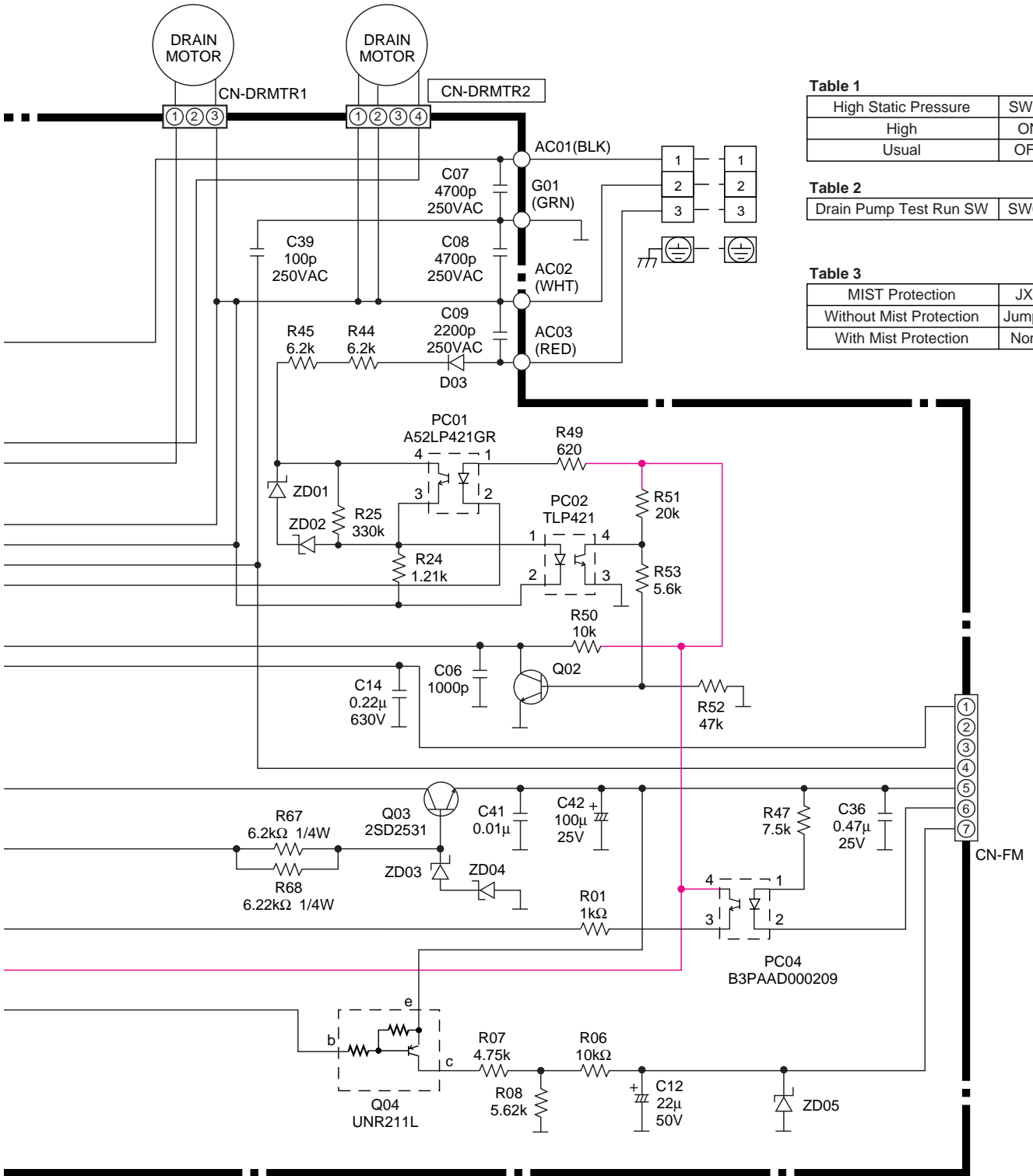

Table 1

High Static Pressure	SW01
High	ON
Usual	OFF

Table 2

Drain Pump Test Run SW	SW02
------------------------	------

Table 3

MIST Protection	JX1
Without Mist Protection	Jumper
With Mist Protection	None

18.2. Outdoor Unit

● CU-E15DBE CU-E18DBE CU-E21DBE

SCHEMATIC DIAGRAM 1/4

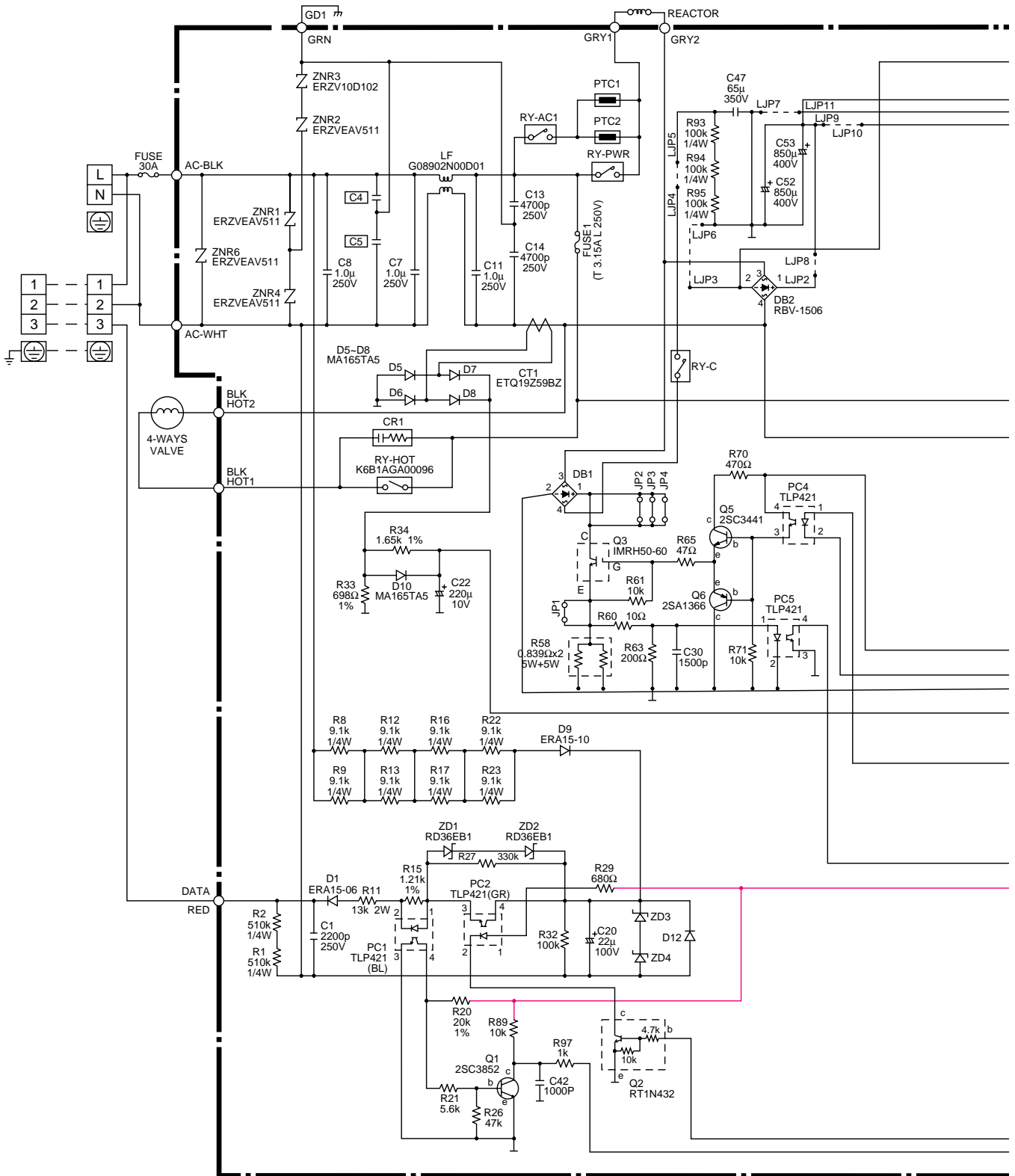

SCHEMATIC DIAGRAM 2/4

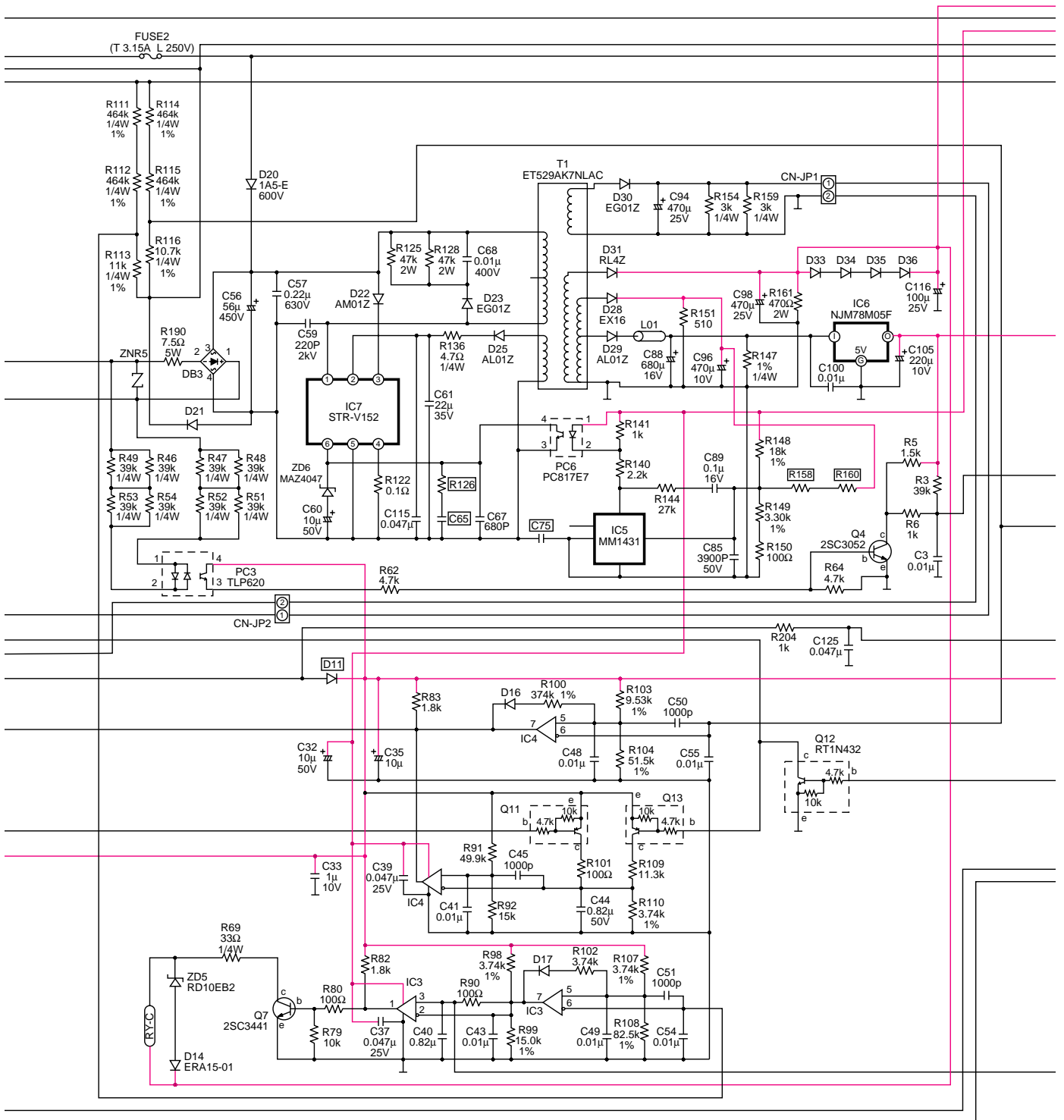

SCHEMATIC DIAGRAM 3/4

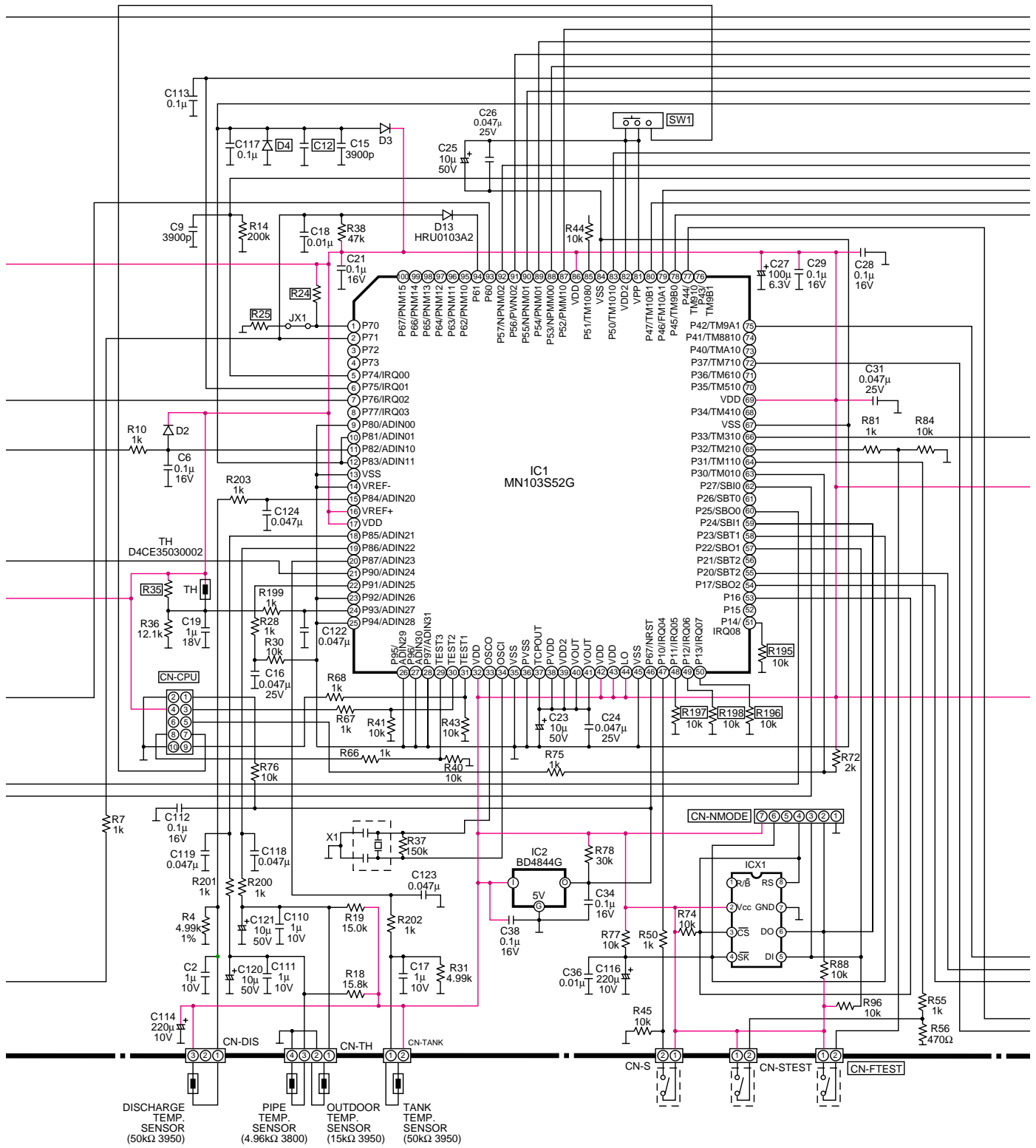

SCHEMATIC DIAGRAM 44

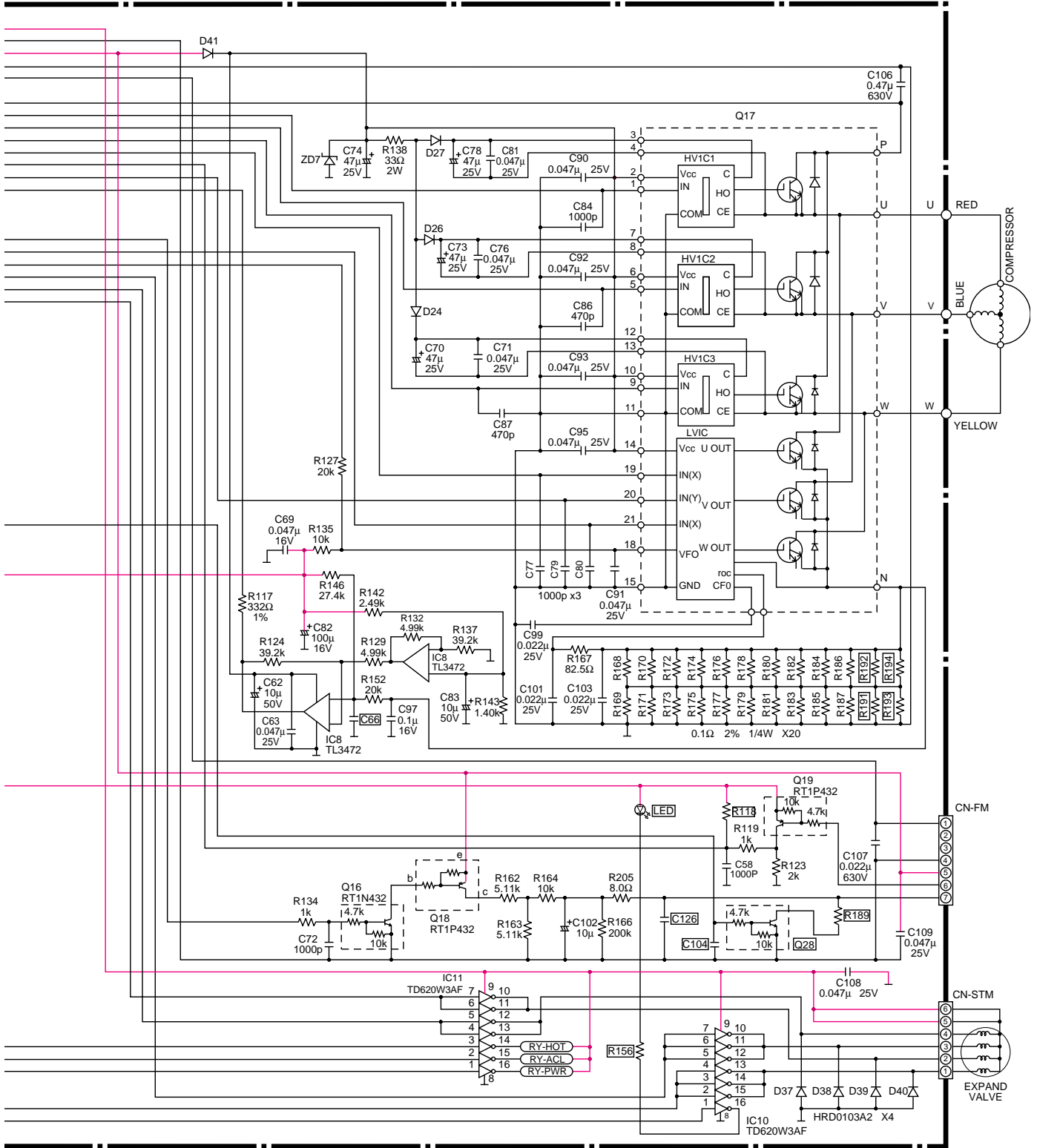

How to use electronic circuit diagram

Before using the circuit diagram, read the following carefully.

- * Voltage measurement
Voltage has been measured with a digital tester when the indoor fan is set at high fan speed under the following conditions without setting the timer.
Use them for servicing.
Voltage indication is in Red at all operations.
- * Indications for resistance
 - a. K...kΩ M...MΩ
 - W...watt Not indicated....1/4W
 - b. Type
 - Not indicated.....carbon resister
 Tolerance±5%
 - metal oxide resister
 Tolerance±1%
- * Indications for capacitor
 - a. Unit μ...μF P...pF
 - b. Type Not indicated....ceramic capacitor
 - (S).....S series aluminium electrolytic capacitor
 - (Z).....Z series aluminium electrolytic capacitor
 - (SU).....SU series aluminium electrolytic capacitor
 - (P).....P series polyester system
 - (SXE).....SXE series aluminium electrolytic capacitor
 - (SRA).....SRA series aluminium electrolytic capacitor
 - (KME).....KME series aluminium electrolytic capacitor
- * Diode without indication.....MA165
- ※ Circuit Diagram is subject to change without notice for further development.

TIMER TABLE <INDOOR>

Name	Time	Test mode (When test point Short-circuited)
4 way valve abnormality	4 min.	24 sec.
Outdoor air temp. for Hz No. decision	30 min.	0 sec.
Anti-dew formation control	20 min.	0 sec.
Anti-freezing control	6 min.	0 sec.
Thermo OFF delay	3 min.	0 sec.
Low pressure control (gas leakage) compressor OFF time	3 min.	0 sec.
Time delay safety control	2 min. 58 sec.	0 sec.
Odour timer status shift time	20 sec.	0 sec.
	90 sec.	
	20 sec.	
	120 sec.	
Intake air temp. sampling time	2 min.	0 sec.
Self diagnosis display time	10 sec.	0 sec.
Auto mode judgement sampling time	20 sec.	0 sec.
24 hours Real Timer	1 hour	1 min.
Heating SSHi fan speed shift	120 min.	12 sec.
Cooling SHi fan speed shift	30 min.	3 sec.
Hot start forced completion	4 min.	0.4 sec.
Auto mode judgement interval	30 min.	3 sec.
After Hot start / Deice	2 min.	12 sec.

TIMER TABLE <OUTDOOR>

Name	Time	Test mode (When test point Short-circuited)
DC PEAK	30 sec.	3 sec.
Deice detection	120 min.	24 sec.
	80 min.	16 sec.
	40 min.	8 sec.
	40 min.	8 sec.
Hz lock time	30 sec.	0 sec.
Outdoor fan delay operation control	30 sec.	3 sec.
4 way valve delay operation control	3 min.	18 sec.

18.3. Remote Control

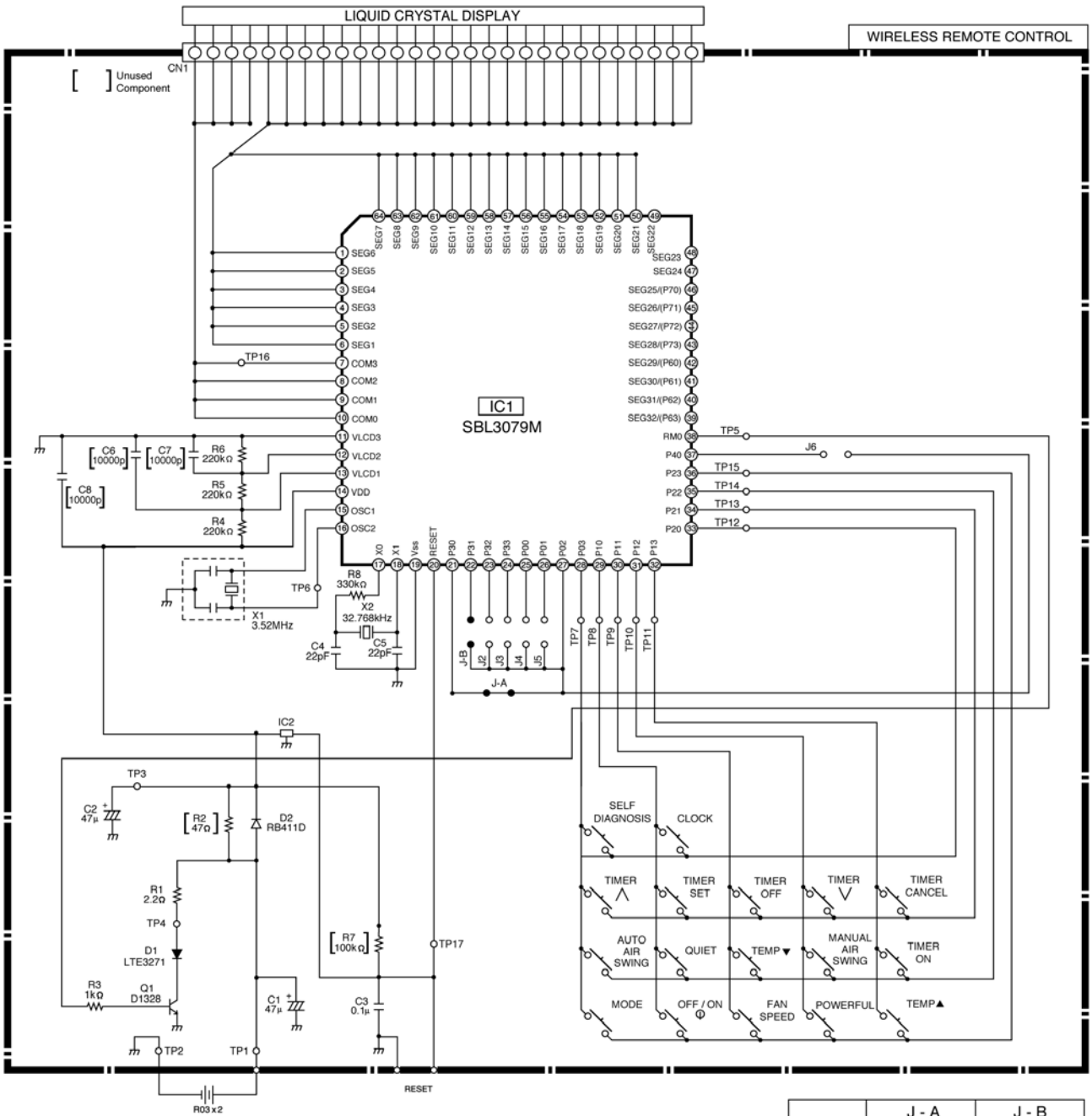

	J - A	J - B
0	SHORT	OPEN
1	OPEN	OPEN
2	SHORT	SHORT
3	OPEN	SHORT

18.4. Print Pattern Indoor Unit Printed Circuit Board

● MAIN

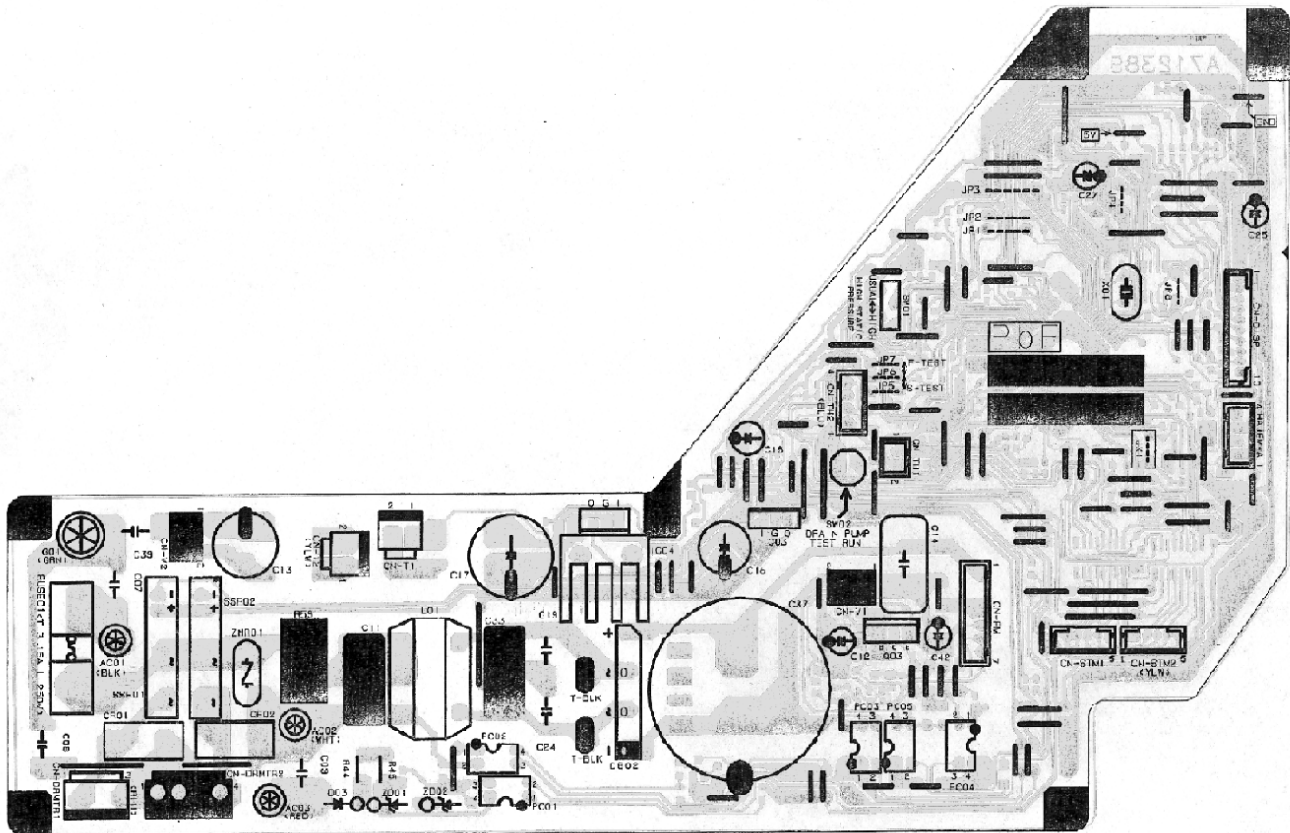

18.5. Print Pattern Outdoor Unit Printed Circuit Board View

- MAIN

